

Christoph Schönherr

MISSA in tempore incerto

für Tenor solo, Chor und C

Dem internationalen Festival
C.H.O.I.R. gewidmet

PROBE-PARTITUR
Evaluation Copy - Quality may be reduced • Carus-Verlag

Klavierauszug

Carus 27.

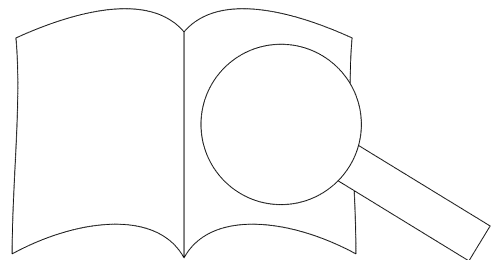

Inhalt

Vorwort des Herausgebers <i>Foreword by the Editor</i>	3
Anmerkungen zur Komposition <i>About the composition</i>	4
Text	5
Kyrie	7
Gloria	12
Credo	24
Sanctus et Benedictus	39
Agnus Dei	44



Veröffentlichungen der Landesakademie für die musizierende Jugend in Baden-Württemberg, herausgegeben von Klaus K. Weigele
Reihe 2: Vokalmusik
Band 4: Christoph Schönherr: *Missa in te more inc*
Kompositionsauftrag der Landesakademie für die musizierende Jugend in Baden-Württemberg

Carus 27.076/03 (Klavierauszug)
ISMN: M-007-09282-5

Zu diesem Werk ist das Folgende erhältlich:
Partitur und Stimmen
Klavierauszug (CD)
Eine CD-Einspielung
Christoph Schönherr: *Missa in te more inc*
Festivalchor C.H.O.I.R. 2008 unter der Leitung von
im Verlag beziehbar (Carus 27.076/99).

Für

Carus
LIEBHERR
MUSIK UND SPORT

LIEBHERR

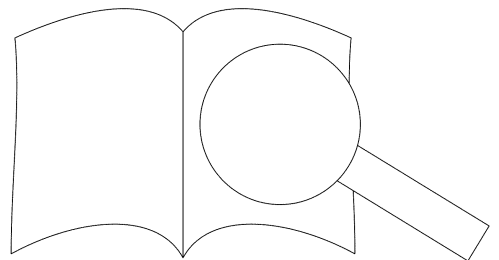

PROBE-PARTITUR
Evaluation Copy - Quality may be reduced • Carus-Verlag

Vorwort des Herausgebers

In der *MISSA in tempore incerto* begegnen sich der seit Jahrhunderten tradierte Messtext des christlichen Abendlandes und eine Musik, deren Sprache in der Verwendung der Idiomatik des Jazz den Bogen zur heutigen Zeit spannt. Gerade die Verbindung der sich vordergründig entgegengesetzten Aspekte von Tradition und Moderne kann der heranwachsenden Generation kulturelles Erbe auf der Folie ihrer eigenen Lebenswelt näher bringen. Die Musik des Werkes spricht eine Vielzahl junger Menschen an und öffnet somit den Blick für kulturelle Wurzeln. Dies ermöglicht dem Einzelnen, auf die vielen offenen Fragen einer globalisierten Welt in unsicheren, schweren Zeiten individuelle Antworten zu finden.

Neue Wege bei der Vermittlung kultureller Traditionen zu suchen und zu beschreiten ist neben Fortbildungs- und Begabtenfördermaßnahmen eine der zentralen Aufgaben der Landesakademie für die musizierende Jugend in Baden-Württemberg. Mit der Veröffentlichung dieses Werkes möchten wir zudem neue Impulse für aktives Musizieren geben. Aufgrund seines Schwierigkeitsgrades ist das Werk für qualifizierte Schul-, Jugend- und andere Chöre geeignet.

Ochsenhausen, Mai 2008

Klaus K. Weigele
Akademiedirektor

Editor's Foreword

In the *MISSA in tempore incerto*, the text of the centuries-old Mass in the western Christian tradition encounters a musical language which with its use of jazz idioms spans a bridge to the present. Precisely this combination of seemingly antithetical aspects, traditional and modern, can bring a cultural heritage closer to the up and coming generation against the backdrop of the world they are living in. The music in this piece addresses a multitude of young people, thereby making them aware of their cultural roots. This will enable each of them to find individual answers to the many questions posed by a globalized world in uncertain, difficult times.

Together with furthering education and nurturing talented students, the discovery and implementation of ways to impart cultural traditions is one of the core tasks of the State Academy of Youth Music in Ochsenhausen. By publishing this piece we also hope to provide impulses for active music-making. Despite its difficulty, the work is suitable for school and other choirs.

Ochsenhausen, May 2008
Translation: Peter Pal

Besetzung:

Solo (Tenor):
Der Part kann mit Mikrofon gesungen werden.
Chor S(S)ATB(B)
Instrumente:
2 Trompeten
2 Violinen
Klavier
Drumset (optional)
Original evtl. gemindert
Achtung: Der Text ist in italienischer Sprache.
Achtung: Der Text ist in italienischer Sprache.
Uraufgeführt am 03.08.2008, Ochsenhausen

Scoring:

Solo (Tenor):
The solo tenor part can be sung with a microphone.
Chor S(S)ATB(B)
Instruments:
2 trumpets
2 violins,
piano, electric
drum set
Concerning
The choir should
Duration: ca. 30 min.
First performed

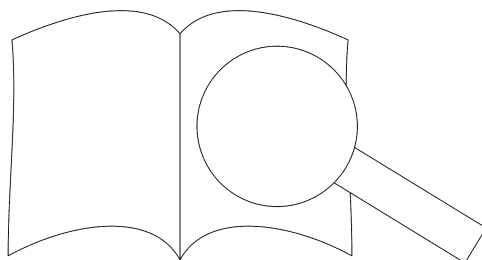

Anmerkungen zur Komposition

In der vorliegenden Messe muss die Gewichtung der einzelnen Teile des Ordinariums im Zusammenhang mit dem Titelzusatz des Werkes gesehen werden:

MISSA in tempore incerto – Messe in schwerer Zeit. Am Anfang des 21. Jahrhunderts zeichnen sich globale Bedrohungen ab, die die Menschheit in ungeahnter Weise herausfordern werden. Diese Tatsache leitete mich bei der Neuvertonung des Messetextes. Die Musik steht im Spannungsfeld zwischen flehentlicher Bitte, Hilferuf und Hoffnung. Für die musikalische Ausdeutung sah ich vor allem im Blues und in den Latin-Stilen angemessene und zeitgemäße Tonsprachen. Trotz – aber auch gerade wegen der inhaltlichen Vorgabe durch den Titelzusatz „in ungewisser bzw. unsicherer Zeit“ ist die Grundstimmung der Messe keine resignative, sondern eine zuversichtliche, so findet z. B. das anfängliche d-Moll im *Kyrie* schließlich in ein D-Dur im *Amen*, das die Messe beschließt.

Wie schon mein *Magnificat – The Groovy Version of OX* ist auch diese Komposition dem internationalen Festivalchor C.H.O.I.R. gewidmet. In diesem Chor singen jedes Jahr Jugendliche aus vielen Ländern Europas gemeinsam und schließen Freundschaften, die hoffentlich helfen werden, schwere Zeiten zu bestehen.

Insel Poel, im Mai 2008

Christoph Schönherr

About the composition

In the present Mass the weight of the individual sections of the Ordinary must be seen in connection with the subtitle of the work:

MISSA in tempore incerto – Mass in a difficult time. The beginning of the 21st century is beset by threats to the planet that will pose undreamt-of challenges to humanity. It was this thought that guided me in my new setting of the text of the Mass. The music oscillates between fervent entreaties, cries for help, and hope. For the musical exegesis I found suitable and contemporary idioms in blues and Latin styles in particular. Nonetheless – but also precisely because of the pre-established contents indicated by the phrase “in an uncertain or unsettled time” – the basic mood of this Mass is not one of resignation but one of confidence. Thus the initial D minor key of the *Kyrie* actually finds its way to D major in the *Amen* as the Mass closes.

Like my *Magnificat – The Groovy Version of OX* this composition is dedicated to the international Festivalchor C.H.O.I.R. Every year, young people from many countries sing together in a choir, which, it is hoped, will help them to overcome difficult times.

Insel Poel, May 2008

Translation: Pr

Christoph Schönherr

PROBE-PARTITUR
Ausgabequalität gegenüber Original evtl. gemindert • Evaluation Copy - Quality may be reduced • Carus-Verlag

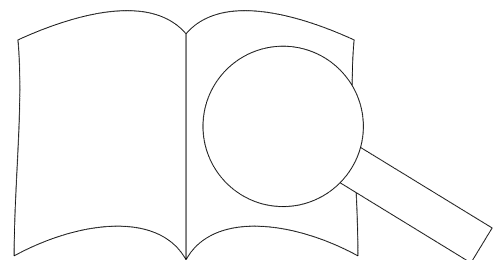

Text

Kyrie

Kyrie eleison.
Christe eleison.
Kyrie eleison.

Kyrie

Herr, erbarme dich unser.
Christus, erbarme dich unser.
Herr, erbarme dich unser.

Kyrie

Lord, have mercy on us.
Christ, have mercy on us.
Lord, have mercy on us.

Gloria

Gloria in excelsis Deo.
Et in terra pax hominibus
bonae voluntatis.
Laudamus te.
Benedicimus te.
Adoramus te.
Glorificamus te.
Gratias agimus tibi propter
magnam gloriam tuam.

Gloria

Ehre sei Gott in der Höhe
und Friede auf Erden den Menschen,
die guten Willens sind.
Wir loben dich.
Wir preisen dich.
Wir beten dich an.
Wir rühmen dich.
Wir danken dir, denn
groß ist deine Herrlichkeit.

Gloria

Glory be to God on high
and on earth peace
to men of good will.
We praise Thee;
we bless Thee;
we adore Thee;
we glorify Thee.
We give Thee thanks
for Thy great glory.

Domine Deus, Rex coelestis,
Deus Pater omnipotens.
Domine Fili unigenite, Jesu Christe.
Domine Deus, Agnus Dei,
Filius Patris.

Herr und Gott, König des Himmels,
Gott und Vater, Herrscher über das All,
Herr, eingeborener Sohn, Jesus Christus.
Herr und Gott, Lamm Gottes,
Sohn des Vaters.

Lord God, heavenly King,
God the almighty Father.
O Lord, the only-begotten
O Lord God, Lamb of God,
Son of the Father.

Qui tollis peccata mundi,
miserere nobis.
Qui tollis peccata mundi,
suscipe deprecationem nostram.
Qui sedes ad dexteram Patris,
miserere nobis.

Du nimmst hinweg die Sünden der Welt:
erbarme dich unser.
Du nimmst hinweg die Sünden der Welt:
nimm an unser Gebet.
Du sitztest zur Rechten des Vaters:
erbarme dich unser.

Thou who take
have mercy
Thou who
receiv
Th
up. ght h
Father,

Quoniam tu solus Sanctus.
Tu solus Dominus.
Tu solus Altissimus,
Jesu Christe.

Denn Du allein bist der Heilige,
Du allein der Herr,
Du allein der Höchste,
Jesus Christus.

alc t
ne,

Cum Sancto Spiritu,
in gloria Dei Patris.
Amen.

Mit dem Heiligen Geist,
zur Ehre Gottes, des Vaters.
Amen.

With
of God the Father.

Credo

Credo in unum Deum,
Patrem omnipotentem,
factorem coeli et terrae,
visibilem [omnium], et invisibilem.
Et in unum Dominum Jesum Christum,
Filius Dei unigenitum.
Et ex Patre natum ante omnia saecula.
Deum de Deo, lumen de lumine,
Deum verum de Deo vero.
Genitum, non factum,
consubstantialem Patri:
per quem omnia facta sunt.

Credo

Ich glaube
den Vater
der alle
die sicht
und an der
s ei
er Zeit:
icht,
in Gott,
affen,
dem Vater;
s geschaffen.

Credo

I believe in one God,
the Father almighty,
Maker of heaven and earth
and of all things visible and invisible.
And in one Lord Jesus Christ,
the only-begotten Son of God,
begotten of his Father before all ages.
God of God, light of light,
true God of true God,
begotten, not made,
being of one substance with the Father,
by whom all things were made.

Qui propter nos homines
nostram salutem de
Et incarnatus est de
ex Maria Virgine
Et homo factus
Crucifixus
sub Pontio Pilato
et

menschen und zu unserem Heil
vom Himmel gekommen.
at Fleisch angenommen durch den
eiligen Geist von der Jungfrau Maria
und ist Mensch geworden.
Er wurde für uns gekreuzigt,
hat unter Pontius Pilatus gelitten
und ist begraben worden.

Who for us men and for our salvation came
down from heaven.
And was incarnate by the Holy Ghost

Er ist am dritten Tag auferstanden
nach der Schrift
und aufgefahren in den Himmel.
Er sitzt zur Rechten des Vaters.
Er wird wiederkommen in Herrlichkeit
zu richten die Lebenden und die Tote

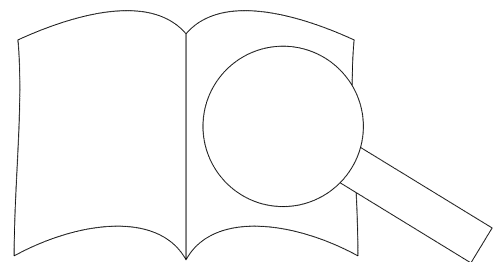

cujus regni non erit finis.
Et in Spiritum Sanctum,
Dominum, [et] vivificantem:
qui ex Patre Filioque procedit.
Qui cum Patre et Filio simul
adoratur, et conglorificatur:
qui locutus est per Prophetas.
Et unum sanctam catholicam
et apostolicam Ecclesiam.
Confiteor unum baptismam
in remissionem peccatorum.
Et expecto resurrectionem mortuorum.
Et vitam venturi saeculi. Amen.

Sanctus et Benedictus

Sanctus, Sanctus, Sanctus.
Pleni sunt coeli et terra
gloria tua.
Hosanna in excelsis.

Benedictus qui venit
in nomine Domini.
Hosanna in excelsis.

Agnus Dei

Agnus Dei, qui tollis peccata mundi:
miserere nobis.
Dona nobis pacem.
Amen.

seiner Herrschaft wird kein Ende sein.
Ich glaube an den Heiligen Geist,
der Herr ist und lebendig macht:
der aus dem Vater und Sohn hervorgeht.
Er wird mit dem Vater und dem Sohn angebetet
und verherrlicht;
der gesprochen hat durch die Propheten.
Ich glaube an die eine, heilige, weltweite und
apostolische Kirche.
Ich bekenne die eine Taufe
zur Vergebung der Sünden.
Ich erwarte die Auferstehung der Toten und
das Leben der kommenden Welt. Amen.

Sanctus et Benedictus

Heilig, heilig, heilig.
Erfüllt sind Himmel und Erde
von deiner Herrlichkeit.
Hosanna in der Höhe.

Hochgelobt sei, der da kommt
im Namen des Herrn.
Hosanna in der Höhe.

Agnus Dei

Lamm Gottes, du nimmst hinweg die Sünde
der Welt: erbarme dich unser.
Gib uns den Frieden.
Amen.

whose kingdom shall have no end.
And I believe in the Holy Ghost,
the Lord and Giver of Life,
who proceedeth from the Father and the Son,
who with the Father and the Son
together is worshipped and glorified,
who spake by the Prophets.
And I believe in one universal
and Apostolic Church.
I acknowledge one Baptism
for the remission of sins.
and I look for the Resurrection of the dead
and the life of the world to come. Amen.

Sanctus et Benedictus

Holy, Holy, Holy.
Heaven and earth
are full of Thy glory.
Hosanna in the highest.

Blessed be He that cometh
in the name of the Lord
Hosanna in the high

Agnus Dei

Lamb of
world
Gr?

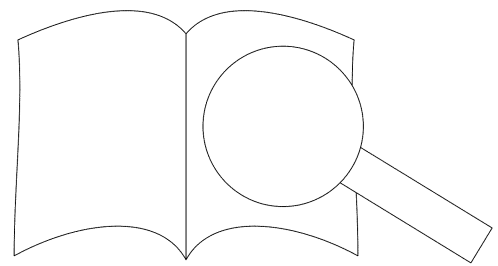
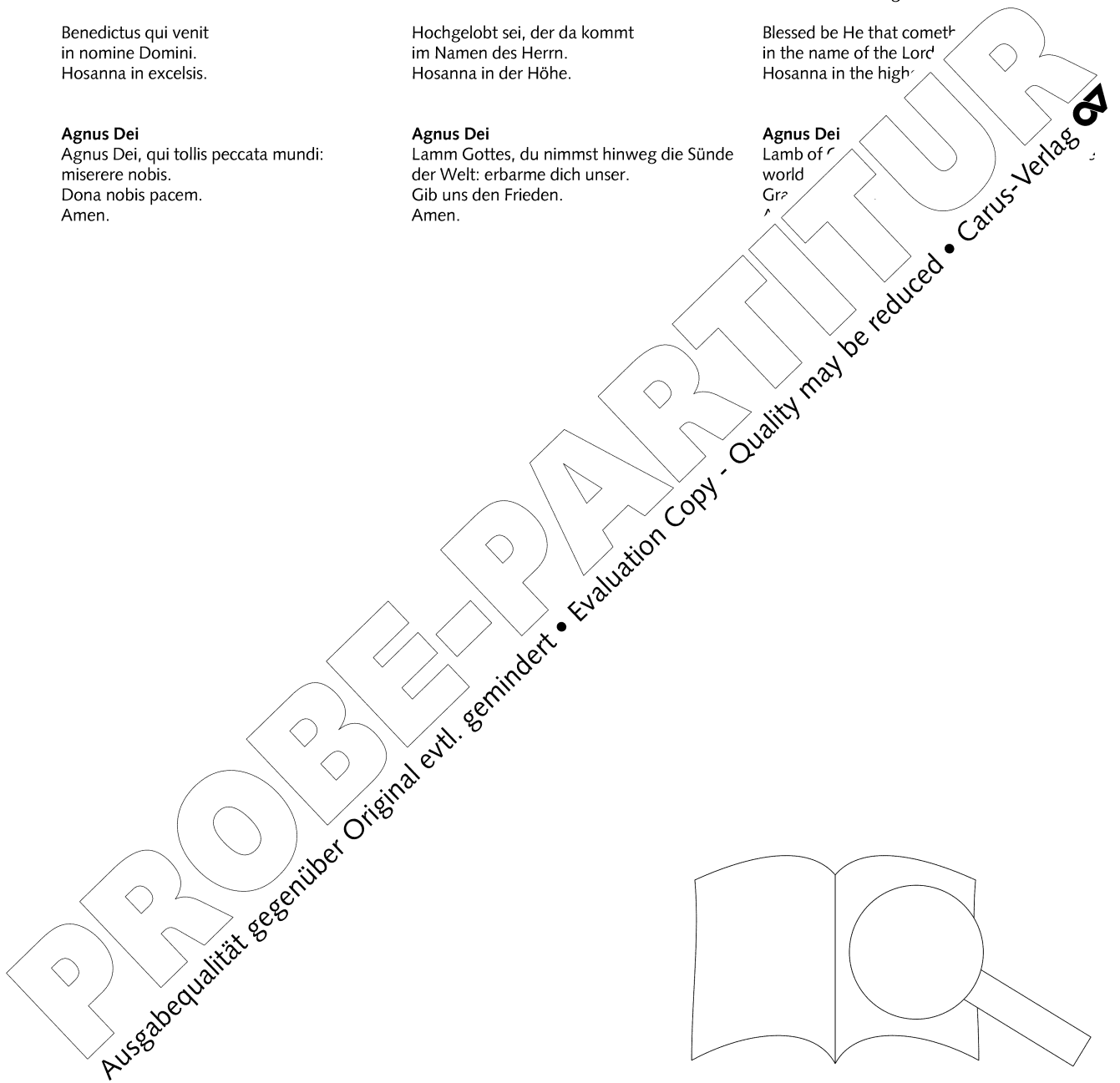

MISSA

in tempore incerto

Kyrie

Christoph Schönherr 2008
(*1952)

Blues feeling ♩ = ca. 80

f quasi recitativo

Tenore solo

Ky-ri - e e - le-i-son, Ky-ri -

Soprano

Ky-ri - e e-le-i-son, _____

Alto

Ky-ri - e e-le-i-son, _____

Tenore

Ky-ri - e e-le-i-son, _____

Basso

Ky-ri - e e-le-i-son, _____

Piano

for rehearsal only

6

e e-le-i-son, e-le-i-son, _____ Ky-ri - e e - le - i-son. _____

_____ e-le-i-son, _____

_____ e e-le-i-son, _____

Ky-ri - e e-le-i-son, _____

Ky-ri - e e-le-i-son, _____

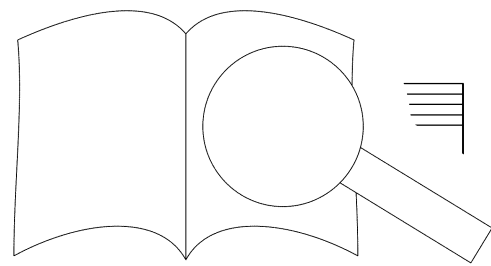

Chri - ste e - lei - son,
Ky - ri - e e - le - i - son, e - le - i - son.
Ky - ri - e e - le - i - son, e - le - i - son.
Ky - ri - e e - le - i - son, e - le - i - son.
e - le - i - son.

play Dm⁷/G Cm⁷ Fsus⁴

Chri - ste e - lei - son,
Chri - ste e - lei - son.
Chri - ste e - lei - son.
Chri - ste e - lei - son.
Chri - ste e - lei - son.
Chri - ste e - lei - son.
Chri - ste e - lei - son.
Chri - ste e - lei - son.

Dm⁷(b5) G⁷(b9) Fsus⁴ Fm⁷ Dm⁷(b5) G⁷(b9) Cm⁷

C

le - i - son,
le - i - son.

D⁷₉ Am⁷

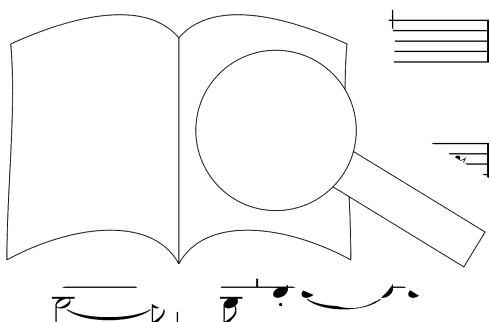

PROBEPARTITUR

Ausgabequalität gegenüber Original evtl. gemindert • Evaluation Copy - Quality may be reduced • Carus-Verlag

D

Chri - ste e - le - i - son.

Hm7(b5) Hm7(b5)/E E7 Amadd2

33 Bbmadd2 Amadd2 CmA9 Amadd2

E

Ky - ri - e e -

- ri - e e -

Bbmadd2 Amadd2 Amadd2

lei - son, -

lei - son, -

lei

Ky - ri - e e - le - i - son, - Ky - ri - e e -

lei - son, - Ky - ri - e e -

Ky - ri - e e - le -

Amadd2 Cm

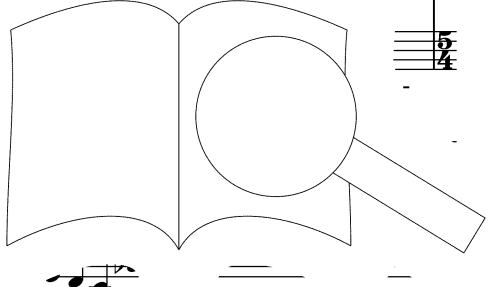

45

lei - son, — Ky - ri - e e - le - i - son, — Ky - ri - e e -

lei - son, — Ky - ri - e e - le - i - son, — Ky - ri - e e -

lei - son, — Ky - ri - e e - le - i - son, — Ky - ri - e e -

lei - son, — Ky - ri - e e - le - i - son, — Ky - ri - e e -

B^bm^{add}2 Am^{add}2 Cm^Δ9 Am^{add}2

49

lei - son, — Ky - ri - e e - le - i - son, —

lei - son, — Ky - ri - e e - le - i - son, —

lei - son, — Ky - ri - e e -

Ky - ri - e e - lei - son, — son, e - lei - son, —

B^bm^{add}2 Am^{add}2 Am^{add}2

53

Ky - ri - e e -

son, — Ky - ri - e e -

le - i - son, — Ky -

le - i - son, — Ky

B^bm^{add}2 Am^{ac}

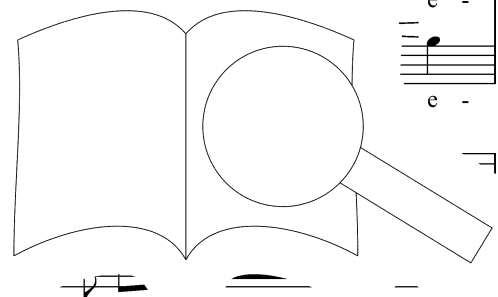

PROBE PARTITUR

Ausgabequalität gegenüber Original evtl. gemindert • Evaluation Copy - Quality may be reduced • Carus-Verlag

Tenore solo

f

8

e - le - i - son, e - le - i - son, e - le - i - son,

le - i - son, *ff* Ky - ri - e e - le - i - son, e - le - i -

le - i - son, *ff* Ky - ri - e e - le - i - son, e - le - i -

le - i - son, *ff* Ky - ri - e e - le - i -

le - i - son, *ff* Ky - ri - e

Cm^{Δ9} *Cm*^{Δ9} *Cm*^{Δ9} *D^bm*^{Δ9}

rit.

8

son, e - le - i - son, e - le - i - son,

son, e - le - i - son, e - le

son, e - le - i - son.

p e - le - i - son.

p e - le - i - son.

p e - le - i - son.

p e - le - i - son.

p e - le - i - son.

- son, *A^baug* for rehearsal on!

Gloria

Latin ♩ = 72

Piano

A[♭]/B[♭] Gm/B[♭] Fm/B[♭] Gm/B[♭] A[♭]/B[♭] Gm/B[♭] Fm/B[♭] G[♭]

A

f Glo - ri - a in ex - cel - sis De - o, in ex - cel - sis
f Glo - ri - a in ex - cel - sis De - o,

B[♭] A[♭]/B[♭] Gm/B[♭] Fr Gm/B[♭] Fm/B[♭]

De - o, glo - ri - a in ex - cel - sis, glo - ri - a in ex -
De - o, glo - ri - a in ex - cel - sis, glo - ri - a in ex -
De - o, glo - ri - a in ex - cel - sis, glo - ri - a in ex -
cel - sis De - o, glo - ri - a in ex -

B[♭] A[♭]/B[♭] G[♭]

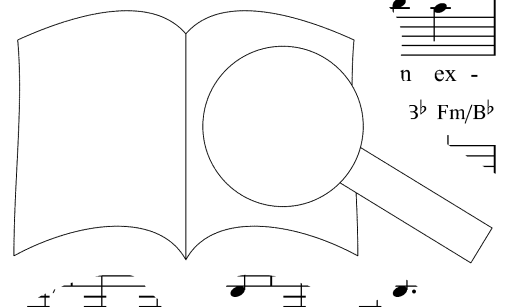

PROBEPARTITUR
Ausgabequalität gegenüber Original evtl. gemindert. Evaluation Copy - Quality may be reduced. Carus-Verlag

B

16

cel - sis De - o.

cel - sis De - o.

cel - sis De - o.

cel - sis De - o.

G^bA B^b B^b open for solo (ruhig) Cm⁹ Dm⁹ Cm⁹

22

Dm⁹ C[#]m⁹ D^{A9} C[#]m⁹

27

Et in ter - ra pax ho - mi - ni -

Et in ter - ni -

C^{A9} solo ends Cm⁹



PROBEPARTITUR
Ausgabequalität gegenüber Original evtl. gemindert • Evaluation Copy - Quality may be reduced • Carus-Verlag

32

Et in ter - ra pax ho - mi - ni - bus bo - nae

bus bo - nae vo - lun - ta - tis.

bus bo - nae vo - lun - ta - tis, bo - nae vo - lun -

Dm⁹ C#m⁹ F#% C#m⁹ F#%

37

vo - lun - ta - tis.

bo - nae vo - lun - ta - tis.

bo - nae vo - lun - ta - tis.

Et in

ta - tis, bo - nae vo - lun - ta

Hm⁷ Hm⁷/D C#s⁷ Cm⁹

42

Et in ter - ra pax ho -

ter ho - mi - ni - bus et in

ho - mi - ni - bus et in

Et in ter - ra pax bo - nae

Cm⁹ Dm⁹

mi - ni - bus bo - nae vo - - - lun - ta - -

ter - ra pax, pax ho - mi - ni -

ter - ra pax, pax ho - mi - ni -

vo - lun - - ta - tis, bo - nae vo - lun - ta - -

C#m9 F#% Hm7 Hm7/D C#sus4(7)

Lau-da-mus te, be - ne -

tis.

bus.

bus.

Dsus4(7) D7

di-ci-mus te, ___ ad-o - ra-mus te, ___ glo-ri-fi - ca-mus te. ___

Lau-da-mus te, ___ be-ne - di-ci-mus te, ___ ad-o -

Lau-da-mus te, ___ be-ne - di-ci-mus te, ___ ad-o -

Lau-da-mus te, ___ be-ne - di-ci-mus te, ___ ad-o -

Lau-da-mus te, ___ be-ne - di-ci-mus te, ___

A/G F#m7 Hm7 G4

ra - mus te, ___ glo-ri - fi - ca - mus te

ra - mus te, ___ glo-ri -

ra - mus ___ Gra - ti - as a - gi - mus ti - bi ___

- ca - mus te. ___ Gra - ti -

E7sus4 Em7 Dm7

PROBEEPARTITUR

Ausgabequalität gegenüber Original evtl. gemindert • Evaluation Copy - Quality may be reduced • Carus-Verlag

66
pro-pter ma-gnam glo-ri-am, ma-gnam glo-ri-am tu-am.
pro-pter ma-gnam glo-ri-am, ma-gnam glo-ri-am tu-am.
pro-pter ma-gnam glo-ri-am, ma-gnam glo-ri-am tu-am.
pro-pter ma-gnam glo-ri-am, ma-gnam glo-ri-am tu-am.
Dm⁷ Em⁷ A^{bΔ9}

71 **G**
Do-mi-ne De-us, Rex coe-le-stis, De-us Pa-ter o-mni-pot-ens.
Do-mi-ne De-us, Rex coe-le-stis, De-us Pa-ter o-mni-pot-ens. li u-ni-
Do-mi-ne De-us, Rex coe-le-stis, De-us Pa-ter o-ni-ens. Fi-li u-ni-
Do-mi-ne De-us, Rex coe-le-stis, De-us Pa-ter o-ni-ens. Do-mi-ne Fi-li u-ni-
G A/G F^{#m7} G^A

76 rit. *p*
ge-ni-te, Je-su Chri-ste. Do-mi-ne De-us, A-gnus De-i,
ge-ni-te, Je-su Chri-ste. Do-mi-ne De-us, A-gnus De-i,
gr Chri-ste, Je-su Chri- De-i,
su Chri-ste, Je-su Chri- De-i,
r⁴ E^{7sus4} Em⁷ Dm⁷ E^{7sus}

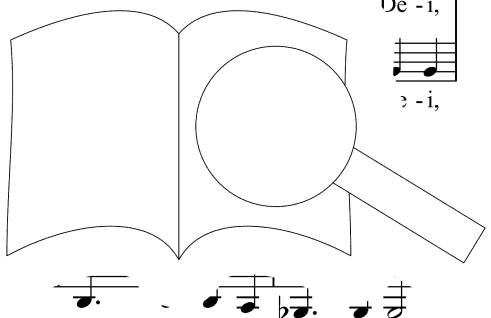

PROBENPARTITUR
Ausgabequalität gegenüber Original evtl. gemindert • Evaluation Copy - Quality may be reduced • Carus-Verlag

H

Tenore solo

$\text{♩} = 100$ quasi recitativo

83

Qui tol-lis pec-ca-ta mun - di,
 Fi - li - us Pa - tris. Mi - se - re - re
 Fi - li - us Pa - tris. Mi - se - re - re_ no - bis, mi - se - re - re
 Fi - li - us Pa - tris. Mi - se - re - re_ no - bis, mi - se re
 Fi - li - us Pa - tris.

Asus⁴ A Gm/B^b Asus⁴⁻³ Gm⁷

90

sus - ci - pe, qui
 no - bis, - pe de - pre - ca - ti - o - nem no - stram. *mf*
 no - bis, sus - ci - pe de - pre - ca - ti - o - nem no - stram. *mf*
 no - ci - pe, sus - ci - pe de - pre - ca - ti - o - nem no - stram. *mf*
 sus - ci - pe, sus - ci ram. *mf*

cresc.
 sus - ci - pe, sus - ci ram. *mf*

Gm Asus^{7/b9} A7(b9) Dm^{add2} A



tol-lis pec-ca-ta mun-di, — mi-se-re-re no-bis. —

Mi-se-re-re no-bis. Qui se-des ad dex-te-ram

Mi-se-re-re no-bis. Qui se-des ad dex-te-ram

Mi-se-re-re no-bis.

Mi-se-re-re no-bis.

Esus^{4/7(b5)} Asus⁴ A Gm⁹ Em^{7(b5)} A

PROBE PARTITUR
Evaluation Copy - Quality may be reduced • Carus-Verlag

Pa-tris, mi-se-re-re no - bis.

Pa-tris, mi-se-re-re no - bis.

mi-se-re-re no - bis.

mi-se-re-re no - bis.

mi-se-re-re no - bis.

mi-se-re-re no - bis.

(b5) Em^{7(b5)/A} A⁷ Em/A

Ausgabequalität gegenüber Original evtl. gemindert • Evaluation Copy - Quality may be reduced • Carus-Verlag

Quo-ni-am tu so-lus
 Quo-ni-am tu so-lus
 Quo-ni-am tu so-lus

F#m/A G/A F#m/A Em/A F/A A G/A
 Quo - ni - am

San - ctus. Tu so - lus Do-mi-nus. Tu so - lus
 San - ctus. Tu so - lus Do-mi-nus. Tu so - lus
 San - ctus. Tu so - lus Do-mi-nus. Tu so - lus
 tu so-lus San-ctus. Tu so-lus Do - so - lus - si-mus,

F#m/A G/A F#m7/A Asus4 F#m7
 tu so-lus San-ctus. Tu so-lus Do - so - lus - si-mus,

decesc. Je - su Chri - ste.
decesc. Je - su Chri - ste. *mf leicht* Cum San - cto Spi - ri - tu, in glo - ri - a,
decesc. Je - su Chri - ste.

Je - su Chri - ste.
 Je - su Chri - ste.
 Je - su Chri - ste.
 Je - su Chri - ste.
 Je - su Chri - ste.
 Je - su Chri - ste.
 Je - su Chri - ste.
 Je - su Chri - ste.

Esus4 Em Dm7 Esus4 E #m7

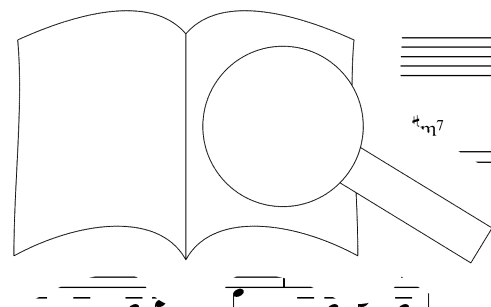

PROBEPARTITUR
 Ausgabequalität gegenüber Original evtl. gemindert • Evaluation Copy - Quality may be reduced • Carus-Verlag

mf leicht

Cum San-cto Spi - ri-tu, in glo - ri-a, glo - ri-a De - i Pa - tris.
 glo - ri-a De - i Pa - tris. Cum San - cto Spi - ri-tu, in glo - ri-a

Cum San-cto Spi-ri-tu, in

F#m7/H E A^Δ F#m7 G#m7 Hm7/E A D^Δ

Cum San - cto Spi - ri-tu, in glo - ri-a De - Pa tris.
 De - i Pa - tris, ri-a De - i Pa - tris.
mf leicht
 Cum ri-a, glo - ri-a De - i Pa - tris.
 glo - ri-a, glo-ri-a in glo-ri-a De - i Pa - tris.

Hm7 C#m7 F# F#m7 G#m7 Hm7/E A

Bbm7 Am7 Am7/D

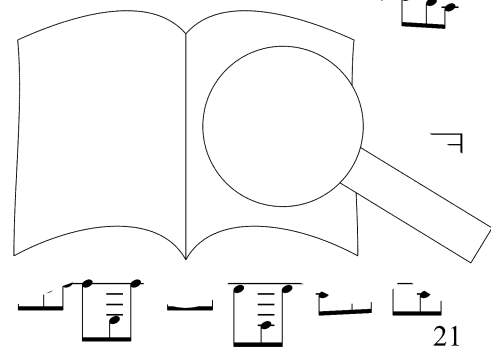

Musical score for measures 142-146. It includes vocal lines and piano accompaniment. The lyrics are: "Cum San-cto Spi - ri-tu, in glo - ri-a,".

Chords: Em⁷/A, D⁹, A⁶/H, E, A^Δ, F[#]m⁷, G[#]m⁷.

Musical score for measures 147-150. It includes vocal lines and piano accompaniment. The lyrics are: "glo - ri - a De - i Pa - tris, ... ri - tu, in Cum San-cto Spi - ri-tu, in glo - ri - a De - i".

Chords: Hm⁷/E, A, D^Δ, F[#]m⁷/H.

Musical score for measures 151-154. It includes vocal lines and piano accompaniment. The lyrics are: "Cum San-cto Spi - ri-a, glo - ri - a De - i Pa - tris, Cum San-cto Spi - ri-tu, in De - i Pa cum San - cto Spi".

Chords: F[#]m⁷, G[#]m⁷, H.

PROBEPARTITUR
 Ausgabequalität gegenüber Original evtl. gemindert • Evaluation Copy - Quality may be reduced • Carus-Verlag

cum San - cto Spi - ri - tu, in glo - ri - a De - i Pa - tris.
 glo - ri - a, glo - ri - a De - i Pa - tris, De - i Pa - tris.
 cum San - cto Spi - ri - tu, in glo - ri - a De - i Pa - tris.
 De - i Pa - tris, in glo - ri - a De - i Pa - tris.

Hm7 C#m7 F#m7/H E C#m7 F#m7 H7 E D/E

N

A - men, a - men, a - men, a - men, a - men.
 A - men, a - men, a - men, a - men,
 A - men, a - men, a - men, a - men,
 A - men, a - men, a - men, a - men, a - men, a - men.

A H/A H₁ A

a - men, a - men, a - men.
 a - men, a - men, a - men.
 a - men, a - men, a - men.
 a - men, a - men, a - men, a - men, a - men.

Hm7 Hm7/E

Credo

Halftime Rock ♩ = 100

Piano

A

17 *mf* ruhig schreitend

Cre - do in u - num De - um, Pa - trem o - mni - pot - en - tem, fa -

mf ruhig schreitend

Cre - do in u - num De - um, Pa - trem o - mni - pot - en - tem

mf ruhig schreitend

Cre - do in u - num De - um, Pa - trem o - mni - po -

mf ruhig schreitend

Cre - do in u - num De - um, Pa - trem o - mni - po -

Chords: C%, C%, Dm9, Dm7/G

22

li et vi - si - bi - li - um, et in - vi - si -

li vi - si - bi - li - um, et in - vi - si -

rae, vi - si - vi - si -

rae, vi - si -

Chords: C%, C%

B

28

bi - li - um. Et in u - num Do - mi - num
 bi - li - um. Et in u - num Do - mi - num
 bi - li - um. Et in u - num Do - mi - num
 bi - li - um. Et in u - num Do - mi - num

mf *mf* *mf* *mf*

A^bΔ⁹ A^bΔ⁹ C% C% Dm⁹

33

Je - sum Chri - stum, Fi - li - um De - i u - ni - ge - ni -
 Je - sum Chri - stum, Fi - li - um De - i u - ni - a - tre
 Je - sum Chri - stum, Fi - li - um De - i ex Pa - tre
 Je - sum Chri - stum, Fi - li - um De ... Et ex Pa - tre

G⁹sus G⁹ C% C% G⁹sus G⁹

38

na - tum a - ni - a sae - cu - la.
 na - tur o - mni - a sae - cu - la.
 na te o - mni - a
 te o - mni - a

F^Δ Em⁷ Dm⁷

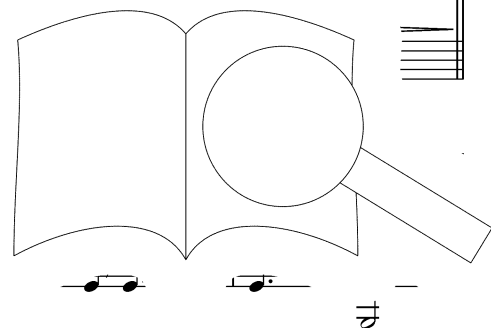

PROBEPARTITUR
 Ausgabequalität gegenüber Original evtl. gemindert • Evaluation Copy - Quality may be reduced • Carus-Verlag

mf Lu - men de lu - mi - ne, —
mf Lu - men de lu - mi - ne, —
mf De - um de De - o, — lu - men de lu - mi - ne, —
mf De - um de De - o, — lu - men de lu - mi - ne, —

C⁶ Em⁷ Dm⁷ G⁷ C⁴

De - um ve - rum de De - o ve - ro. Ge - ni - tum, —
 De - um ve - rum de De - o ve - ro. Ge —
 de De - o ve - ro. — a - ctum, —
 de De - o ve - ro. — on fa - ctum, —

F⁴ Fm⁷ A^{7(b9)} A⁷

mf con - sub - stan - ti - a per quem o - mni - a fa - cta
mf con - sub - stan - ti - a: per quem o - mni - a fa - cta
mf cor Pa - tri: per quem o - mni - a fa - cta
 lem Pa - tri: per quem o - mni - a fa - cta

G^{7/13}

PROBEPARTITUR
 Ausgabequalität gegenüber Original evtl. gemindert • Evaluation Copy - Quality may be reduced • Carus-Verlag

55 Tenore solo

mf **D**

Qui pro-pter nos ho-mi-nes, et pro-pter no-stram sa-lu-tem de-scen-dit, de-

sunt.

sunt.

sunt.

sunt.

C D^b D^b D^b C

61 **p** **mf**

scen-dit, de-scen-dit de coe-lis. ex Ma-

in-car-natus est de Spi-ri-tu San-cto

in-car-natus est de Spi-ri-tu San-cto

pp Et in-car-natus est de Spi-ri-tu San-cto

pp Et in-car-na

E^bm⁷⁽⁴⁻³⁾ Cm^{7(b5)} F D₁

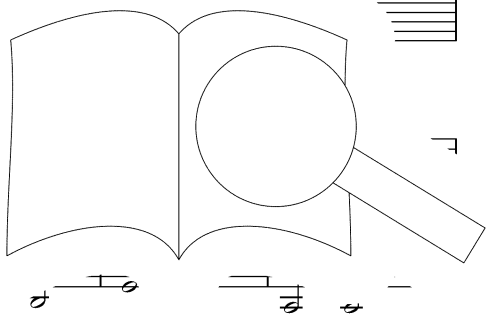

PROBE PARTITUR
 Ausgabqualität gegenüber Original evtl. gemindert • Evaluation Copy - Quality may be reduced • Carus-Verlag

molto rit.

ri - a Vir - gi - ne: Et ho - mo fa - ctus est,
 et ho - mo fa - ctus est.
 et ho - mo fa - ctus est.
 et ho - mo fa - ctus est.
 et ho - mo fa - ctus est.

pp
pp
pp
pp

A^b Gm7(4-3) Fm7 C D^bA

Cruxifixus

F ♩ = 50

Cm Dm7(b5)/C G7(b9)/C Cm Cm

au - ci - fi - xus, cru - ci - fi - xus, cru - ci -
 Cru - ci - fi - xus, cru - ci - fi - xus, cru - ci -
 Cru - ci - fi - xus, cru - ci - fi - xus. cru - ci -
 Cru - ci -

mf
mp
mp
mp

^{b5}/C G7(b9)/C Cm

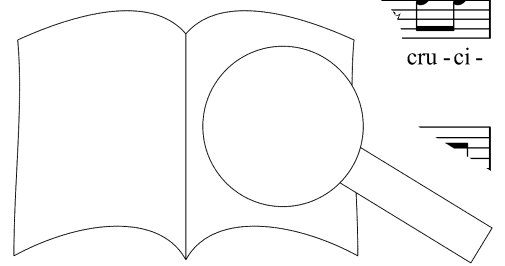

PROBEPARTITUR
 Ausgabqualität gegenüber Original evtl. gemindert • Evaluation Copy - Quality may be reduced • Carus-Verlag

fi - xus, cru-ci - fi - xus, cru-ci - fi - xus, cru-ci - fi - xus, cru-ci-fi - xus,
 fi - xus, cru-ci - fi - xus, cru-ci - fi - xus, cru-ci - fi - xus, cru-ci-fi - xus,
 fi - xus. cru-ci - fi - xus, cru-ci - fi - xus, cru-ci - fi - xus, cru-ci-fi - xus,
 fi - xus, cru-ci - fi - xus, cru-ci - fi - xus, cru-ci - fi - xus, cru-ci - fi - xus, cru-ci-fi - xus,

G7(b9)/C Cm Cm Dm7(b5)/C G7(b9)/C Cm F#o

cru-ci-fi - xus, cru-ci-fi - xus e - ti - am pro no - bis, — bis:
 cru-ci-fi - xus, cru-ci-fi - xus e - ti - am pro no - bis: — bis:
 cru-ci-fi - xus, cru-ci-fi - xus e - ti - ar pro no - bis: — bis:
 cru-ci-fi - xus, cru-ci-fi - xus pro no - bis: — bis:

G7/F Abo/Db C Cr. Dba G7(b9)sus4 G7

H

sub Pon - ti - o Pi - la - to —

Cmadd2 Dbmadd2

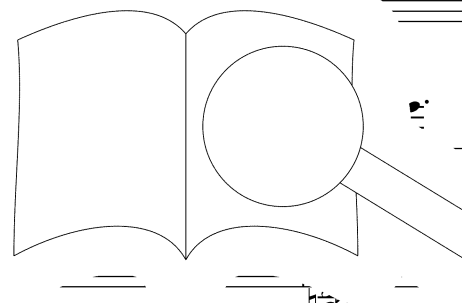

mp

molto rit.

pas - sus, — pas - sus, — pas - - sus, se - pul - tus est.

pas - sus, — pas - sus, — pas - - sus, se - pul - tus est.

pas - sus, — pas - sus, — pas - - sus, se - pul - tus est.

mp

et se - pul - tus est, se - pul - tus est.

Cm^{add2} Cm Fm^{7sus4} Fm⁷ D^{bA9} G Fm⁷ G⁵

I

Jazz waltz ♩ = 160

C^Δ C^Δ Em⁷ Hsus

J

f

Et re-sur - r

re-sur - re - xit ter - ti-a di - e, —

se - cun - dum Scri - ptu - ras, —

f

re-sur - re - xit ter - ti-a

Et re-sur - re - xit ter - ti-a

Scri -

Am⁷

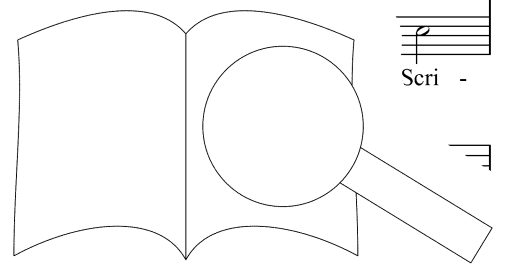

et re-sur - re - xit ter-ti - a di - e se - cun - dum Scri - ptu - ras.
 et re-sur - re - xit ter-ti - a di - e se - cun - dum Scri - ptu - ras.
 di - e, et re-sur - re - xit ter-ti - a di - e se - cun - dum Scri - ptu - ras.
 ptu - ras, et re-sur - re - xit ter-ti - a di - e se - cun - dum Scri - ptu - ras.

Am7 Dm7 Dm7/G E7/G# E7 Am7 Dm7/G G13(b9) C C

Tenore solo *mf poco a poco cresc.*

Et a - scen - dit, - - - - - at,

Am7 Am7 D9 D9 Am7

et a - scen - dit in
 se - det ad dex - te - ram
 se - det ad dex - te - ram

Am7 D9 D9

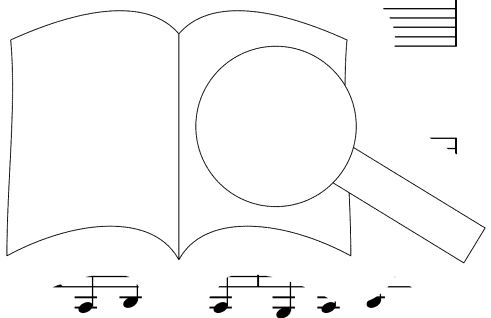

Pa - tris, Pa - tris. ad dex - te - ram Pa - tris, Pa - tris, ad dex - te - ram Pa - tris, Pa - tris.

se - det ad dex - te - ram Pa - tris, Pa - tris.

se - det ad dex - te - ram Pa - tris, Pa - tris.

Am⁷ Hsus⁴ H C^Δ Hm⁷ Am⁷ Am⁷/D D

M

Swing ♩ = 138

G% Am⁷ Am⁷/D G%

Am⁷ Am⁷/D G% Em⁷ E^{b7}

N

et et

- rum ven - tu - rus est cum

i - te - rum ven - tu - rus est

C^{Δ9} Am⁷

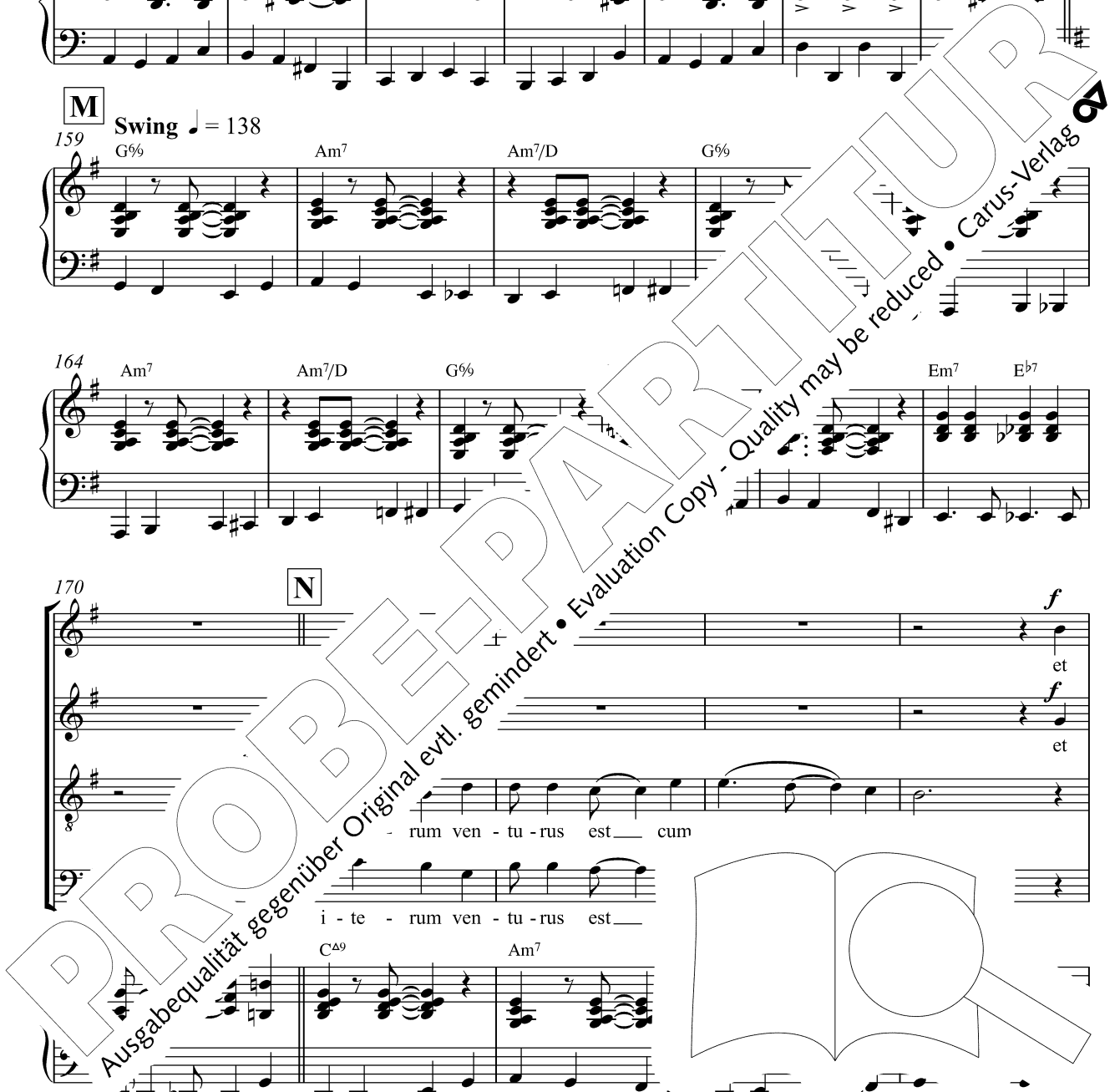

i - te - rum ven - tu - rus est cum glo - ri - a,
 i - te - rum ven - tu - rus est cum glo - ri - a,
 ju - di - ca - re
 ju - di - ca - re

G6% Am7 Am7/D G6% F#m7

et mor - tu - os: cu - jus
 et mor - tu - os: cu - jus
 vi - vos et mor - tu - os: gni,
 vi - vos et mor - tu - os: re - gni,

p *mf* **O**

H7 Em7 Eb7 Am7/D CA

cu - jus e - rit fi - -
 non e - rit fi - -
 non
 e - gni non

Am9 Am7/D

PROBEPARTITUR
 Ausgabegüte gegenüber Original evtl. gemindert • Evaluation Copy - Quality may be reduced • Carus-Verlag

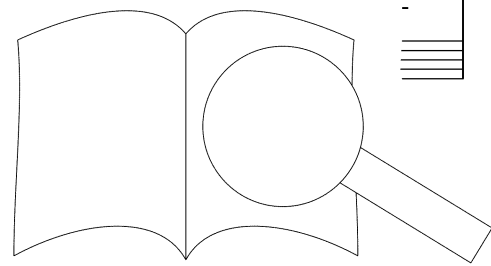

P Et in Spiritum Sanctum
Halftime Rock ♩ = 100

190

Tenore solo

rit.

non e - rit fi - nis.

mf ruhig schreitend

nis. Et in Spi-ri-tum San-ctum, Do-mi-num, vi-vi-fi-

mf ruhig schreitend

nis. Et in Spi-ri-tum San-ctum, Do-mi-num, vi-vi-fi-

nis.

nis.

G^{bΔ} Fm⁶/G G⁷ C% C%

196

can-tem: qui ex Pa-tre t. si-mul ad-o-

can-tem: qui ex Pa-tre ro-cc-dit. si-mul ad-o-

mf ruhig schreitend

Qui cum Pa-tre et Fi-li-o

mf ruhig schreitend

n⁷/G G⁹ C%

ra - tur, qui lo - cu - tus est per Pro - phe - tas.

ra - tur, qui lo - cu - tus est per Pro - phe - tas.

et con - glo - ri - fi - ca - tur: qui lo - cu - tus est per Pro - phe - tas.

et con - glo - ri - fi - ca - tur: qui lo - cu - tus est per Pro - phe - tas.

Dm⁹ Dm⁹/G G⁹ A^bΔ⁹ A^bΔ⁹ C⁶/₉

Et u - nam san - ctam

Et u - nam san - ctam et a - po -

Et u - nam san - ctam et a - po -

Et u - nam san - ctam et a - po -

Et u - nam san - ctam et a - po -

Et u - nam san - ctam et a - po -

C⁶/₉ Dm⁹ Dm⁹/G G⁷/₉ C⁶/₉ Dm⁹

sto - li - cam Ec -

sto - li - cam

sto

- si - am.

C⁶/₉ F^Δ Em⁷ Dm⁷

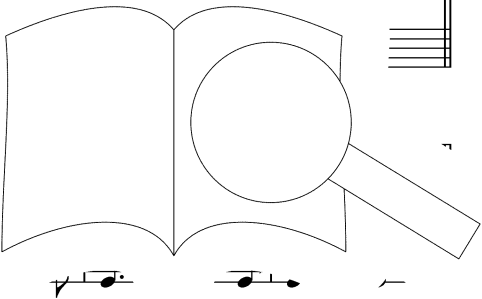

219 **R**

Tenore solo *f*

Con - fi - te - or - u - num ba - ptis - ma in re - mis - si - o - nem pec - ca - to - rum. Et ex -

Fm/A^b Cm/G D7/F# Gm

226

spe - cto re - sur - re - cti - o - nem mor - tu - o - rum.

Et ex - spe - cto re - sur - re - cti - o - nem mor - tu - o - rum.

Et ex - spe - cto re - sur - re - cti - o - nem mor - tu - o - rum.

Et ex - spe - cto re - sur - re - cti - o - nem mor - tu - o - rum.

Et ex - spe - cto re - sur - re - cti - o - nem mor - tu - o - rum.

G G7 Cmadd2 Cm G Cm

232 **S** *funky*

Cadd2 Em7 Gsus4

236

Et

Et

Em7 Dm7

240 **T**

f

Et vi - tam_ven - tu - ri sae - cu - li. A - men, a - men,

Et vi - tam_ven - tu - ri sae - cu - li. A - men, a - men,

vi - tam_ven - tu - ri sae - cu - li. A - men, a - men, - a - men, a - men,

vi - tam_ven - tu - ri sae - cu - li. A - men, a - men, - et

Cadd2 Em7 Ebm7 Dm7 Gsus4

244

et vi - tam_ven - tu - ri sae - cu - li.

et vi - tam ven - tu - ri sae - cu - li. A - men,

et vi - tam_ven - tu - ri sae - cu - li. A - men, a - men,

vi - tam_ven - tu - ri sae - cu - li. a - men, a - men,

Cadd2 Em7 Gsus4 Fm/A^b

248

vi - tam, - et vi - tam - ven - tu - ri -

Et vi - tam - ven - tu - ri -

et vi - tam, -

A^b9

251

sae - cu - li, et vi - tam, et vi - tam, et vi - tam ven - tu - ri
 sae - cu - li, et vi - tam, et vi - tam, et vi - tam ven - tu - ri
 sae - cu - li, et vi - tam ven - tu - ri sae - cu - li.
 sae - cu - li, et vi - tam ven - tu - ri sae - cu - li.

Fm7 Gadd2 Am9 AbΔ9

254

sae - cu - li. A - men, a - men, a - men, et vi - tam
 sae - cu - li. A - men, a - men, et en
 A - men, a - men, - ri
 A - men, a - men, ven - tu - ri

Fm9 Fm7 Gadd2 Em7

258

sae - cu - li. - men, a - men, a - - men.
 sae - cu - en, a - men, a - men, a - - men.
 A - men, a - men, - men.
 A - men, a - men, - en.

Gsus4 Ab

rit.

PROBEPARTITUR
 Ausgabequalität gegenüber Original evtl. gemindert • Evaluation Copy - Quality may be reduced • Carus-Verlag

Sanctus et Benedictus

♩ = ca. 60

Soprano
Alto
Tenore
Basso

San - ctus, San - ctus, San - ctus.
San - ctus, San - ctus, San - ctus.
San - ctus, San - ctus, San - ctus.
San - ctus, San - ctus, San - ctus.

for rehearsal only
E♭ Fm E F#m F F/Gm

Piano

8 A Latin feel ♩ = 126

Ple - ni sunt coe - li et ter - ra glo - ri - a, glo - ri - a
Ple - ni sunt coe - li et ter - ra glo - ri - a, glo - ri - a
Ple - ni sunt coe - li et ter - ra glo - ri - a, glo - ri - a
Ple - ni sunt coe - li et ter - ra glo - ri - a, glo - ri - a, tu -

play fadd2 Gm7/F Am7/F Gm/C Am/C Gm/C F/C

13 B

tu - a. - - -
tu - a. - - -
tu - a. - - -
- - - ni sunt coe - li et a,
- - - ni sunt coe - li et a,
- - - ni sunt coe - li et a,
- - - ni sunt coe - li et a,
- - - ni sunt coe - li et a,

fadd2 Gm7/F

glo - ri - a, glo - ri - a, glo - ri - a tu - - a.

glo - ri - a, glo - ri - a, glo - ri - a tu - - a.

glo - ri - a, glo - ri - a, glo - ri - a tu - - a.

— glo - ri - a, glo - ri - a tu - - a.

Am/C Gm/C F/C Cm/A^b B^bm/A^b A^b B^bm⁷ Cm/B^b B^bm Csus⁹ C



Ho - san - na in ex - cel - sis, —

Ho - san - na in ex - cel - sis, —

Ho - san - na in ex - cel - sis, —

in ex -

Ho - - - san - na - - - ex - - -

D^b E^b/D^b

- cel - sis, —

- cel - sis, —

ho - san - na in ex - - cel - sis, —

ho - san - na in ex

ho - - -

B^bm⁷

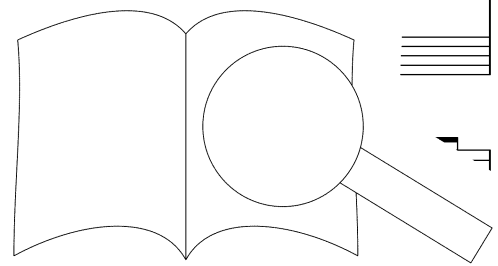

PROBEPARTITUR
Ausgabequalität gegenüber Original evtl. gemindert • Evaluation Copy - Quality may be reduced • Carus-Verlag

29

ho-san-na in ex - cel - sis, ho-san-na in ex - cel - sis.

ho-san-na in ex - cel - sis, ho-san-na in ex - cel - sis.

ho-san-na in ex - cel - sis, ho-san-na in ex - cel - sis.

in ex - cel - sis, ho-san-na in ex - cel - sis.

C7/E Fm7 Gm7 C N.C.

D Benedictus
 33 Blues feeling ♩ = 60 (swing 16th)

Tenor solo

Be-ne .u. in

Fadd2 A♭/F Gm/F Fadd2 A♭/F Gm/F

39

no - mi - ne Do - mi - ni, be - ne -

F^A Gm7/F Fadd2 Gm/F Fadd2 A♭/F Gm/F

45 **E**

it in no - mi - ne Do - mi

F^A Gm7/C

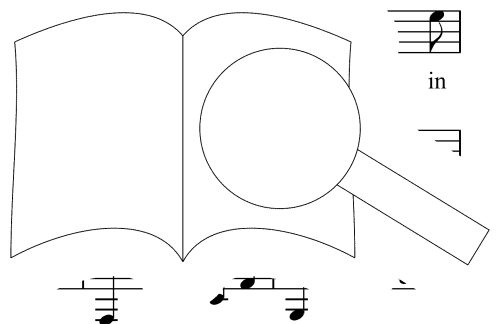

51

no-mi-ne Do-mi-ni, in no-mi-ne Do-mi-ni.

D^bΔ *Cm⁷* *B^bm⁷* *Fadd²/C* *Gm⁷/C* *Gm⁷/C*

56 **F** *pp*

Be - ne - di - ctus qui ve - nit in no - mi - ne

pp

Be - ne - di - ctus qui ve - nit in no - mi

Fadd² *Gm⁷/F* *F^Δ* *Gm⁷/F* *m.* *B^bΔ*

62

ni.

ni.

B^bm⁷ *Fadd²*

68 **G** Latin feel ♩ = 126

Ho-san-na in ex - cel - sis, ho-san-na in ex - cel - sis,
Ho-san-na in ex - cel - sis, ho-san-na in ex - cel - sis,
Ho-san-na in ex - cel - sis, ho-san-na in ex - cel - sis,
Ho - san - na in ex - cel - sis,

D^b E^b/D^b Cm⁷ Fm⁷

72 ho-san-na in ex - cel - sis, ho-san-na in ex -
ho-san-na in ex - cel - sis, ho-san-na in
ho-san-na in ex - cel - sis, ho-san-na in ex -
ho - san - na cel - sis, in ex -

B^bm⁷ H⁰⁷ Dm⁷

76 cel - sis, ho-san-na in ex - cel - sis.
cel - sis, ho-san-na in ex - cel - sis.
cel - sis, sis, F

C

PROBEPARTITUR
Ausgabequalität gegenüber Original evtl. gemindert • Evaluation Copy - Quality may be reduced • Carus-Verlag

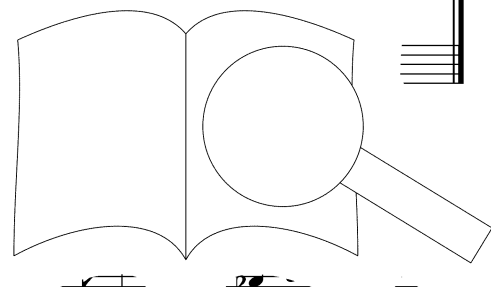

Agnus Dei

Blues feeling ♩ = 52

flehend

Tenore solo

Piano

Musical notation for measures 1-4. Tenor solo part with lyrics "A - gnus". Piano accompaniment with chords Amadd2, Eb7(13), Amadd2, D7(13).

5

Musical notation for measures 5-8. Tenor solo part with lyrics "De - i, A - gnus De - i, qui tol-lis pec - ca - ta". Piano accompaniment with chords F7, E7, Amadd2, F#o7, E7, FΔ.

11

Musical notation for measures 9-10. Tenor solo part with lyrics "mun - di. A - gnus". Piano accompaniment with chords H7(b9), E7, Amadd2, Eb7(1), D7(13).

17

Musical notation for measures 11-16. Tenor solo part with lyrics "De - i, gnus De - i, qui". Piano accompaniment with chords E7, Amadd2. Includes a section labeled "A" and a diagram of a book.

44

Carus 27.076/03

tol - lis pec - ca - ta mun - - - di.

qui tol - lis pec - ca - ta mun - - - di. *p*

qui tol - lis pec - ca - ta mun - - - di. *p*

qui tol - lis pec - ca - ta mun - - - di. *p*

pec - ca - ta mun - - - di. *p*

F^Δ F^{♯m7(b5)} H^{7(b9)} Esus⁷ E⁷ Am^{add2}

27 *mf* **B** A - gnus *f* A - gnus

mf De - i, *f* A - gnus

De - i, *f* A - gnus

gnus De - i, *f* gnus

F⁷

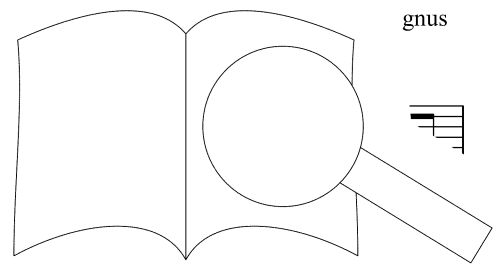

De - i, qui tol - lis pec - ca - ta mun - - -

De - i, qui tol - lis pec - ca - ta mun - - -

De - i, qui tol - lis pec - ca - ta mun - - -

De - i, qui tol - lis pec - ca - ta mun - - -

F#o7 E7 F#m7(b5) H7(b9) E7(b13)

Tenore solo



f

Mi - se - re - re no - bis, - - -

di: - - - re no - bis,

di: - - - se - re - re no - bis,

di: - - - mi - se - re - re, mi - se - re - re,

Eb7(13) Amadd2

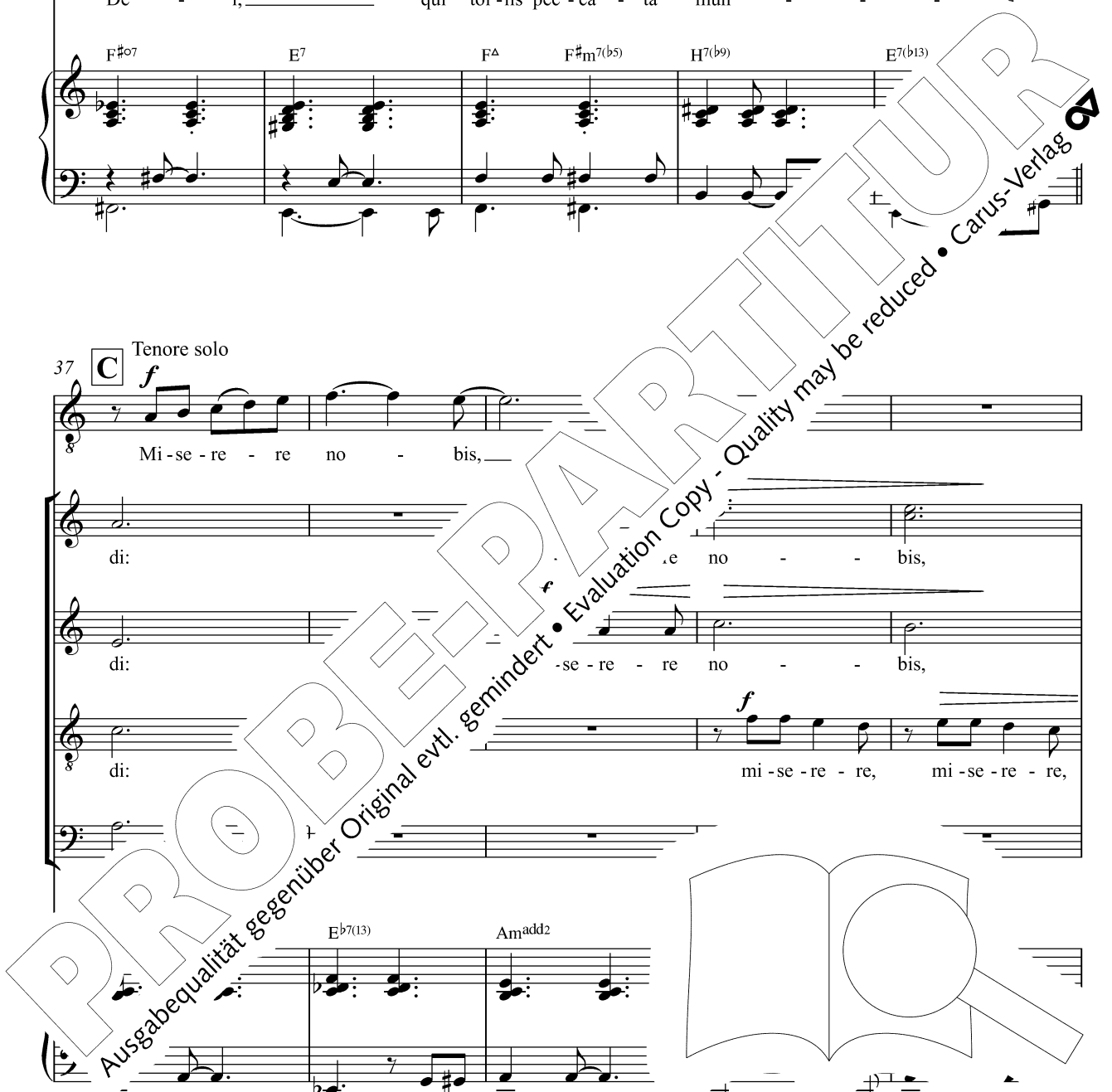

mf
mi - se - re - re, mi - se - re - re, mi - se - re - re no - bis.
mf
mi - se - re - re, mi - se - re - re, mi - se - re - re no - bis.
mf
mi - se - re - re no - bis, mi - se - re - re no - bis.
mf
mi - se - re - re, mi - se - re - re, mi - se - re - re no - bis.
E \flat A9(13) Am/D E \flat A Am⁷ Esus⁷ E⁷

47 **D** Latin Rock ♩ = 132

mi - se - re - re no - bis
A add² G^A/A A add² A add²

pa - cem. Do - na no - bis,
A add² G^A/A



E

no - bis pa - cem. _ Do - na no - bis

- cem, _ pa - cem. _

Do - na no - bis pa - - - - - cem, _

C^A Asus⁴ A Dadd² C^A/D Dadd²

pa - cem, _ do - na no - bis, no - bis

Do - na no - bis pa - - - - - em,

pa - cem, do - na no - pa - cem,

pa - cem,

C^A/D Hm⁷ Bbm⁷(#5) Am⁷ Fadd²

F

pa - cem. _

pa - - - - - bis

G^A/A Aadd²



Do - na no - bis pa - - - - - cem, -

pa - - - - - cem, - pa - cem, do - na

Do - na no - bis

G^A/A A^{add2} G^A/A F^{#m7}

pa - cem, no - bis pa - cem. -

no - bis, no - bis pa -

pa - cem, -

Em⁹ C^{A9} D^{add2}

G

pa - - - - - na no - bis pa - - - - -

pa - - - - - cem, - pa - - - - -

Do

D^{add2}

- cem, - pa - cem, pa - cem.
 do - na no - bis - pa - cem, pa - cem.
 do - na no - bis, - no - bis pa - cem.
 Do - na no - bis pa - - - cem, pa - cem.

Hm7 Bbm7(#5) Am7 Am7/D D

H

A - men, a - men, a - men, a
 A - men, a - men, a - me
 A - men, a - men, a
 A - men, a - men,

G A/G A - r Em7

a - men, a - men, a - men,
 a - men, a - men,
 men, a
 a - men, a

Dm7 BbΔ

PROBEPARTITUR

Ausgabequalität gegenüber Original evtl. gemindert • Evaluation Copy - Quality may be reduced • Carus-Verlag

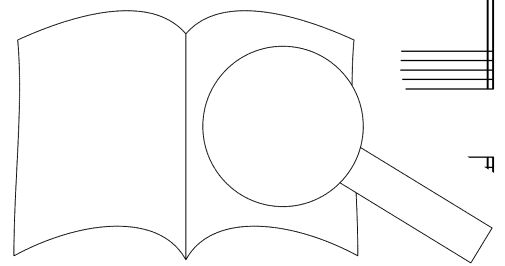

a - men, a - men, a - men, a - men,
 a - men, a - men, a - men, a - men,
 a - men, a - men, a - men, a - men,
 a - men, a - men, a - men, a - men,

G A/G F Δ Em⁷

a - men, a - men, a - men, a
 a - men, a - men, a - men,
 a - men, a - men, a
 a - men, a - men, a - men,

E $\flat\Delta$ Dm⁷

a - men, a a - men, a - men,
 a - men a - men, a - men,
 a men, a
 men, a

D B $\flat\Delta$

Bach, C. P. E.: Magnificat Wq 215	● 33.215/03	- Lauda Sion op. 73	● 40.077/03
- Das große Heilig Wq 217	● 33.217/03	- Lobgesang. Sinfonie-Kantate op. 52	40.076/03
Bach, J. C. F.: Die Pilgrime auf Golgatha	◇ 34.104/03	- Magnificat in D	40.484/03
Bach, J. E.: Deutsches Magnificat	30.303/03	- O Haupt voll Blut und Wunden (Choralkantate)	● 40.186/03
Bach, J. S.: ca. 140 Kantaten (Sonderprospekt)		- Paulus op. 36	40.129/03
- Himmelfahrtsoratorium BWV 11	31.011/03	- Tu es Petrus op. 111	40.480/03
- h-Moll-Messe BWV 232	△ ● 31.232/03	- Verleih uns Frieden gnädiglich (Choralkantate)	● 40.481/03
- Johannespassion 1749 BWV 245	31.245/03	- Vom Himmel hoch (Choralkantate)	● ◇ 40.189/03
- Johannespassion 1725 (enthält nur die Varianten zu 1749)	31.245/53	- Wer nur den lieben Gott läßt walten (Choralkantate)	● 40.132/03
- Magnificat in D BWV 243	31.243/03	- Wir glauben all an einen Gott (Choralkantate)	● 40.187/03
- Markuspassion BWV 247	31.247/03	Mozart: Alma Dei Creatoris KV 277	40.050/03
- Matthäuspassion BWV 244	31.244/03	- Benedictus sit Deus KV 117	40.044/03
- Missa in F BWV 233	31.233/03	- Davide penitente KV 469	40.060/03
- Missa in A BWV 234	31.234/03	- Dixit et Magnificat KV 193	● 40.052/03
- Missa in g BWV 235	31.235/03	- Drei geistliche Hymnen (Thamos-Chöre) KV 345	● 40.032/03
- Missa in G BWV 236	31.236/03	- Exsultate, jubilate KV 165	40.767/03
- Osteroratorium BWV 249	31.249/03	- Grabmusik KV 42	40.045/03
- Weihnachtsoratorium BWV 248	31.248/53	- Hosanna in G KV 223	40.034/03
Beethoven: Missa in C op. 86	40.688/03	- Inter natos mulierum KV 72	40.033/03
- Missa solemnis op. 123	40.689/03	- Kyrie in d KV 341	40.037/03
Berlioz: L'Enfance du Christ op. 25	70.038/03	- Litaniae Lauretanae BMV (KV 109 + KV 195)	40.054/03+40.056/03
Biber: Missa Sti. Henrici	40.676/03	- Litaniae de venerabili altaris Sacramento KV 125	40.055/03
Brahms: Ave Maria op. 12	● 40.180/03	- Litaniae de venerabili altaris Sacramento KV 243	40.057/03
- Der 13. Psalm	40.182/03	- Misericordias Domini KV 222	40.040/03
- Ein Deutsches Requiem op. 45	● 27.055/03	- Missa brevis in G KV 49	40.621/03
Buxtehude: Also hat Gott die Welt geliebt BuxWV 5	36.010/03	- Missa brevis in d KV 65	◇ 40.622/03
- Das jüngste Gericht	● 36.019/03	- Missa in C (Dominicusmesse) KV 66	13/03
- Membra Jesu nostri	● 36.013/03	- Missa in c (Waisenhausmesse) KV 139	1/03
Cherubini: Krönungsmesse in G	40.087/03	- Missa brevis in G KV 140	1/03
- Requiem in c	40.086/03	- Missa in C (Trinitatismesse) KV 167	
Dittersdorf: Missa solemnis in C	27.035/03	- Missa brevis in F KV 192	
Dvořák: Messe in D op. 86	40.653/03	- Missa brevis in D KV 194	
Fauré: Requiem op. 48 (sinfonische Fassung, 1900)	27.312/03	- Missa in C (Spatzenmesse) KV 220	
- Requiem op. 48 (Fassung mit kleinem Orchester, 1889)	27.311/03	- Missa in C (Credomesse) KV 257	
Franck, César: Die Sieben Worte Jesu	◇ 40.095/03	- Missa in C (Spaurmesse) KV 258	
- Messe in A op. 12	40.646/50	- Missa in C (Orgelsolomesse) KV 2f	
Gatti: Schöpfungsmesse in A nach Joseph Haydn	27.053/03	- Missa longa in C KV 262	13
Gounod: Requiem in C	27.315/03	- Missa brevis in B KV 275	3/03
Graun: Der Tod Jesu	10.379/09	- Missa in C (Krönungsmesse)	618/03
Händel: Brockes-Passion HWV 48	55.048/03	- Missa solemnis in C KV 2	+0.619/03
- Israel in Egypt HWV 54	● 55.054/03	- Missa in c KV 427	51.427/03
- Messiah/Messias HWV 56	55.056/03	- Missa in c KV 427)	40.620/03
- Ode for St. Cecilia's Day (Cäcilienode) HWV 76	10.372/03	- Regina coeli in C	47/03+40.049/03
- O praise the Lord. Anthem HWV 254	● 40.911/03	- Regina coeli in	40.048/03
Hasse: Cleofide (Opera seria, Dresden 1731)	50.704/03	- Requiem KV	51.626/53
- Marc' Antonio e Cleopatra (Serenata)	50.702/03	- Requiem	40.630/03
- Beatus vir (Ps 111)	40.969/03	- Requiem	51.626/03
- Confitebor tibi (Ps 110)	40.968/03	- Sancti	● 40.053/03
- Dixit Dominus (Ps 109)	40.966/03	- Sancti	40.768/03
- Laudate pueri (Ps 112)	40.970/03	- Sancti	40.038/03+40.039/03
- Requiem in Es	50.709/03	- Sancti	40.046/03
Haydn, Joseph: Die Schöpfung	50.990/03	- Sancti	40.043/03
- Missa brevis in F	40.601/03	- Sancti	40.041/03
- Missa brevis St. Joannis de Deo in B (Kleine Orgelsolomesse)	40.602/03	- Sancti	40.059/03
- Missa Cellensis (Kleine Mariazeller Messe)	40.6	- Sancti	40.058/03
- Missa Cellensis in honorem BV/M in C (Cäcilienmesse)	40.6	- Sancti	40.645/03
- Missa in angustis (Nelsonmesse)		- Sancti	27.403/03
- Missa in honorem BV/M in Es (Große Orgelsolomesse)		- Sancti	◇ 40.907/03
- Missa in tempore belli (Paukenmesse)		- Sancti	● 50.164/03
- Missa „Rorate coeli desuper“ in G		- Sancti	50.020/03
- Missa Sancti Bernardi von Offida in B (Heiligmesse)		- Sancti	50.126/03
- Missa Sancti Nicolai in G (Nikolaimesse)		- Sancti	● 50.172/03
- Missa in B (Harmoniemesse)		- Sancti	50.169/03
- Missa in B (Schöpfungsmesse)		- Sancti	50.060/03
- Missa in B (Theresienmesse)		- Sancti	50.016/03
Haydn, Johann M.: Missa Beatissimae Vir	50	- Sancti	40.650/03
- Missa in honorem Sanctae Ursulae N	51	- Sancti	40.674/03
- Missa Sancti Hieronymi MH 254	49/03	- Sancti	40.805/03
- Missa sub titulo Sanctae Theresiae	837/03	- Sancti	70.089/03
- Missa sub titulo Sancti Francisci	4.838/03	- Sancti	40.678/03
- Missa sub titulo Sancti Leonardi	50.321/03	- Sancti	40.455/03/53
- Requiem in B MH 838	◇ 50.348/03	- Sancti	◇ 40.942/03
- Requiem in c MH 154	54.638/03	- Sancti	70.060/03
- Vesperae solennes	27.048/03	- Sancti	● 70.053/03
- Weihnachtsresponsum	40.196/03	- Sancti	40.675/03
Heinichen: Missa	40.197/03	- Sancti	40.656/03-40.660/03
Herzogenberg:	40.198/03	- Sancti	70.054/03-70.057/03
- Die Passion in c	◇ 27.020/03	- Sancti	70.047/03-70.052/03
- Erntedankfest	● 50.501/03	- Sancti	70.043/03
- Maria	● 37.103/03	- Sancti	20.435/03
- Marienloben	● 37.104/03	- Sancti	40.085/03
- Maria	35.304/03	- Sancti	39.137/03
- Marienloben	◇ 7.201/03	- Sancti	39.117/03
- Marienloben	● 40.185/03	- Sancti	19.105/03
- Marienloben	◇ 40.797/03	- Sancti	9.134/03
- Marienloben	40.131/03	- Sancti	2.494/03
- Marienloben	● 40.184/03	- Sancti	17/03
- Marienloben	40.130/03	- Sancti	
- Marienloben	40.483/03	- Sancti	
- Marienloben	40.124/03	- Sancti	
- Marienloben	● 40.165/03	- Sancti	
- Marienloben	● 40.188/03	- Sancti	
- Kyrie in d	● ◇ 40.182/03	- Sancti	

PROBEPARTITUR
 Ausgabehalt gegenüber Original evtl. gemindert
 Evaluation Copy - Quality may be reduced
 Carus-Verlag

