

Leopold

# MOZART

---

## Missa solemnis in C

Soli (SATB), Coro (SATB)  
Flauto, 2 Corni, 2 Trombe, Timpani  
2 Violini, Viola e Basso continuo  
(Violoncello / Contrabbasso, Organo)

herausgegeben von / edited by  
Reinhold Kubik

Stuttgarter Mozart-Ausgaben  
Urtext

Klavierauszug / Vocal score  
Paul Horn



---

Carus 27.008/03

# Missa solemnis in C

## Kyrie

Leopold Mozart

1719–1787

### 1. Kyrie eleison

Klavierauszug: Paul Horn (1922–2016)

**Adagio**

Soprano  
Ky - ri - e, Ky - ri - e e - lei - - - - son, e - lei -

Alto  
Ky - ri - e, Ky - ri - e e - lei - son, e - lei -

Tenore  
-

Basso  
-

2 Trombe  
Timpani  
2 Corni  
Archi  
Basso continuo

The first system of the musical score is for the vocal parts and the keyboard accompaniment. It features four vocal staves (Soprano, Alto, Tenor, Bass) and a grand staff for the keyboard (Basso continuo, 2 Trombe, Timpani, 2 Corni, and Archi). The tempo is marked 'Adagio'. The lyrics for the Soprano and Alto parts are 'Ky - ri - e, Ky - ri - e e - lei - - - - son, e - lei -'. The Tenor and Bass parts are marked with a dash, indicating they are silent in this system. The keyboard part begins with a treble clef and a key signature of one flat (C major). A large diagonal watermark 'PROBEPARTITUR' is overlaid across the score.

son, e - lei - - - - ri - e e - lei - son.

son, Ky - ri - e, l son, e - lei - - - - son.

e, Ky - - - - son, e - lei - - - - son.

Ky ri - e e - lei - son, Ky son.

The second system of the musical score continues the vocal parts and keyboard accompaniment. It features four vocal staves and a grand staff for the keyboard. The lyrics for the Soprano part are 'son, e - lei - - - - ri - e e - lei - son.'. The Alto part has 'son, Ky - ri - e, l son, e - lei - - - - son.'. The Tenor part has 'e, Ky - - - - son, e - lei - - - - son.'. The Bass part has 'Ky ri - e e - lei - son, Ky son.'. The keyboard part continues with the same instrumentation as the first system. A large diagonal watermark 'PROBEPARTITUR' is overlaid across the score.

Aufl. ...sdauer / Duration: ca. 50 min.

© 20... by Carus-Verlag, Stuttgart – 3. Auflage / 3rd Printing 2019 – CV 27.008/03

Vervielfältigungen jeglicher Art sind gesetzlich verboten. / Any unauthorized reproduction is prohibited by law.

Alle Rechte vorbehalten / All rights reserved / Printed in Germany / www.carus-verlag.com

edited by Reinhold Kubik

8 **Allegro**  
Tutti  
*f*

11 *fp*

13

16

18 *fp*

21 *f*

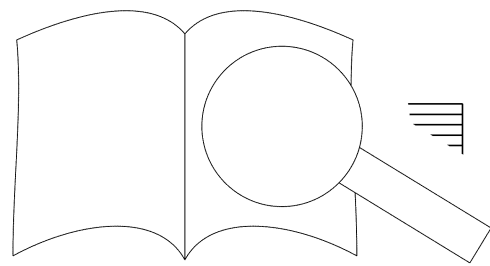

PROBEPARTITUR  
Ausgabequalität gegenüber Original evtl. gemindert • Evaluation Copy - Quality may be reduced • Carus-Verlag

24

Chri - ste e - lei - son, Chri - ste e - lei - son. Ky - ri - e e - lei - son, e -

Chri - ste e - lei - son, Chri - ste e - lei - son. Ky - ri - e e - lei - son, e -

Chri - ste e - lei - son, Chri - ste e - lei - son. Ky - ri - e e - lei - son, e -

Chri - ste e - lei - son, Chri - ste e - lei - son. Ky - ri - e e - lei - son, e -

27

lei - - - - son. Chri - ste, Chri - ste e - lei -

lei - - - - son, e - lei - son, oi. son,

lei - son, e - lei - son, e - lei - son. Chri - - - lei - - - lei - son,

lei - - - - son, e - son, e - lei - son,

30

e - lei - son.

e - lei - son, e - lei - son, e - lei -

e - lei - son, e - lei - son, e -

e - lei - son,

e - lei - son,

33

son. Ky - - - ri - e e - lei - - - son, e -

lei - - - son, e - lei - - - son, e -

lei - son. Ky - - - ri - e e - lei - - -

lei - son. Chri - ste e - lei - - - son, e - lei - -

35

lei - - - son, e - lei - - - son, e -

lei - - - son, e - lei - - - son, e -

son, e - lei - - son, e -

son, e - lei - - son, e -

38

lei - son, e - lei - - - son. Chri - ste e - lei - son, Chri - ste e -

lei - son, e - - - son, e - lei - son, Chri - ste e - lei - son, Chri - ste e -

lei - - - son, e - lei - son, Chri - ste e - lei - son, Chri - ste e -

lei - son, e - lei - son, Chri - ste e - lei - son, Chri - ste e -

41

lei - - - son.

lei - - - # - son.

lei - - - son.

lei - - - son.

*tr*

*f*

44

*tr*

*tr*

*fp*

*fp*

47 Soprano solo

Chri - ste e - lei - son, Chri Ky - ri - e e - lei - son, e -

Bc Archi

*p*

*f*

*f*

*p*

50

- lei - son, e - lei - s n, e -

*f*

*fp*

PROBENPARTITUR

Evaluation Copy - Quality may be reduced • Carus-Verlag

Ausgabequalität gegenüber Original evtl. gemindert

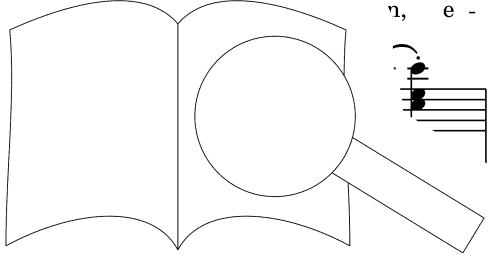

54

Alto solo

lei - son, e - lei - son. Chri - ste e - lei - son, Chri - ste e - lei - son.

Bc Archi Bc Archi

*fp* *f* *p* *fp* *fp*

57

Ky - ri - e e - lei - son, e - lei - son, e - lei - son, e - lei - son,

*tr* *tr* *tr*

60

lei - son, e - lei - son, e - lei - son, e - lei -

*fp* *fp*

63

Tutti Chri - ste e - lei - son.

Tutti Chri - ste e - lei - son.

son.

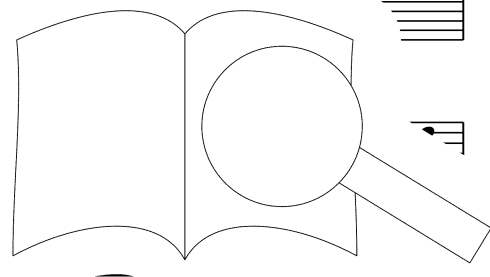

PROBE PARTITUR  
 Ausgabequalität gegenüber Original evtl. gemindert • Evaluation Copy - Quality may be reduced • Carus-Verlag

66

Ky - ri - e e - lei - son, Ky - ri - e e - lei - son, e - lei - - - -

Ky - ri - e e - lei - son, Ky - ri - e e - lei - son, e - lei - - - -

Ky - ri - e e - lei - son, Ky - ri - e e - lei - son, e - lei - son, e - lei - son, e -

Ky - ri - e e - lei - son, Ky - ri - e e - lei - son, e - lei - - - -

69

son. Chri - ste, Chri - ste e - lei - son, e - lei - son,

son, e - lei - son, e - lei - son, e - lei - son.

lei - son. Chri - ste e - lei - son, e - - - - son,

son, e - lei - son, e - lei - son, e - lei - son,

72

e - lei - son, e - lei - son, e - lei - son. Ky - ri - e

e - lei - son, e - lei - - - - son, e -

e - lei - son,

e - lei - son,

ri -

ri -

PROBEKOPPIERT  
 Ausgabequalität gegenüber Original evtl. gemindert • Evaluation Copy - Quality may be reduced • Carus-Verlag



75

e - lei - - - son, e - lei - - - son, e -  
lei - - - son, e - lei - - - son, e -  
e e - lei - - - son, e - lei - son, e -  
e e - lei - - - son, e - lei - son, e -

The musical score for measures 75-77 consists of five staves. The top four staves are for voices (Soprano, Alto, Tenor, Bass) and the bottom staff is for piano. The piano accompaniment includes a triplet of eighth notes in the right hand.

78

lei - son, e-lei - son, e - lei - son, e-lei - son, e - lei -  
lei - son, e-lei - son, e - lei - son, ., Ky-ri -  
lei - son, e-lei - son, e - lei - son, e - lei - son, Ky-ri -  
lei - son, e-lei - son, e - lei - son, e - lei - son, e - lei - son, e -

The musical score for measures 78-80 consists of five staves. The top four staves are for voices and the bottom staff is for piano. Dynamic markings *fp* are present in the piano accompaniment.

81

e e - lei - son - - - son, e - lei - son.  
e e - lei - - - son, e - lei - son.  
e e - - - son, e - lei - son.  
e e - lei - - - son, e - lei - son.

The musical score for measures 81-83 consists of five staves. The top four staves are for voices and the bottom staff is for piano. The piano accompaniment includes a *fz* dynamic marking.

PROBEKOPPIERT  
Ausgabequalität gegenüber Original evtl. gemindert • Evaluation Copy - Quality may be reduced • Carus-Verlag

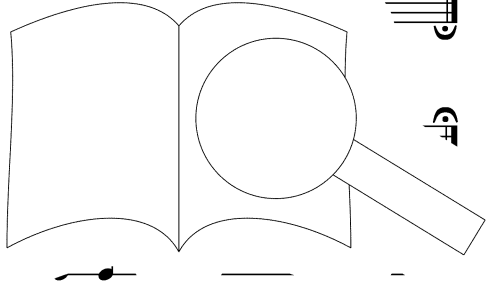

# Gloria

## 2. Gloria in excelsis

**Allegro**

2 Trombe  
Timpani  
2 Corni  
Archi  
Basso continuo

Archi

Cor

Timp

Archi

Cor

Timp

11

Soprano

Alto

Tenore

Basso

Glo - ri - a in ex - cel - sis

Glo - ri - a in ex - cel - sis

Glo - ri - a in ex - cel - sis

Glo - ri - a in ex - cel - sis

14

glo - ri - a in ex - cel - sis, in ex -

glo - ri - a in ex - cel - sis, in ex -

glo - ri - a in ex - cel - sis, in ex -

glo - ri - a in ex - cel - sis, in ex -

glo - ri - a in ex - cel - sis, in ex -

glo - ri - a in ex - cel - sis, in ex -

PROBENFÜR  
Ausgabequalität gegenüber Original evtl. gemindert • Evaluation Copy - Quality may be reduced • Carus-Verlag

17

cel - sis, in ex - cel - sis, in ex - cel - sis

ex - cel - sis, in ex - cel - sis

cel - sis, in ex - cel - sis, in ex - cel - sis

20

De - o. Et

sis De - o. - ra

sis De - o. in ter - ra

sis De - o. in ter - ra

24

pax, in ter - ra pax, pax, pax ho -

pax, in ter - ra pax, pax, pax ho -

pax, in ter - ra pax, pax, pax ho -

ra pax, in ter - ra

28

Solo

mi - ni - bus bo - nae vo - lun - ta - tis,

Solo

mi - ni - bus bo - nae vo - lun - ta - tis, bo - nae vo - lun - ta - tis,

Solo

mi - ni - bus bo - nae vo - lun - ta - tis,

mi - ni - bus

33

Tutti

bo - nae vo - lun - ta -

Tutti

bo - nae vo - lun - ta -

Tutti

bo - nae vo - lun - ta - tis, bo - nae vo - lun - ta -

bo - nae vo - lun - ta -

38

tis.

tis.

tis.

tr

PROBENPARTITUR

Ausgabequalität gegenüber Original evtl. gemindert • Evaluation Copy - Quality may be reduced • Carus-Verlag

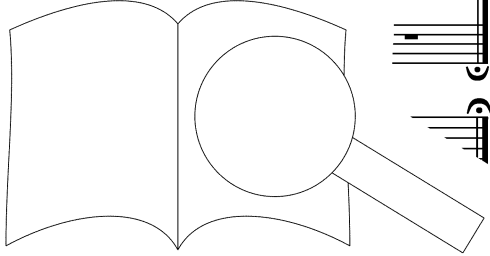

### 3. Laudamus te

Un poco allegro e grazioso

2 Corni  
Archi  
Basso continuo

11 Soprano solo

Lau - s u - ius de - i lau -

17

da - - - mus te, - mus te, lau -

22

be-ne - di - ci-mus te, lo -

28

ri - fi - ca - mus, glo - ri - fi - ca -

34

- mus te, ad - o - ra - mus, glo - ri - fi - ca - mus te,

40

ad - o - ra - mus, glo - ri - fi - ca - mus te.

45

Lau - da - mus te, lau -

50

lau - da - - - mus te

PROBEPARTITUR  
 Ausgabequalität gegenüber Original evtl. gemindert • Evaluation Copy - Quality may be reduced • Carus-Verlag

56

— lau - da - - - mus te, be-ne-di - - - ci-mus te,

61

ad - o - ra - - - mus te, ad - o - ra - - -

67

- - mus te, glo - ri - fi - ca-mus, glo - ri

74

80

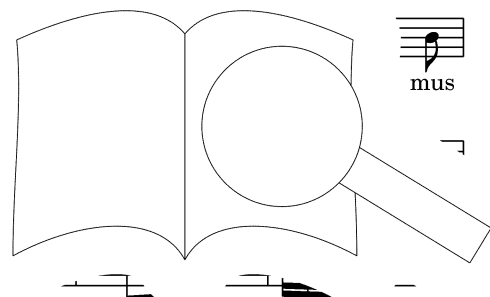

mus

86

te, ad - o - ra - mus, glo - ri - fi - ca - mus te,

92

ad - o - ra - mus, glo - ri - fi - ca - mus te, glo - ri - fi - ca - mus te, glo fi -

98

ca - - - mus te.

104

110

chl: Ausbequalität gegenüber Original evtl. gemindert • Evaluation Copy - Quality may be reduced • Carus-Verlag

auszierung der Fermate / suggestion for ornamentation:

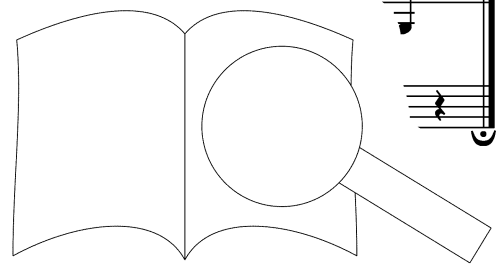



# 4. Gratias agimus tibi

Adagio

Soprano

Gra - ti - as a - - - gi-mus ti - - - bi, gra - ti - as

Alto

Gra - ti - as a - gi-mus ti - - - bi,

Tenore

Gra - ti - as a - gi-mus ti - - - bi,

Basso

Gra - ti - as a - gi-mus ti - - - bi,

2 Trombe

Timpani

2 Corni

Archi

Basso continuo

Archi

4

a - - - gi-mus ti - - bi pro - pter ma - - -

gra - ti - as a - gi-mus ti - - bi pro - - - a - am,

gra - ti - as a - gi-mus ti - - bi - - - ri-am tu - am,

gra - ti - as a - gi-mus ti - - - am glo - ri-am tu - am,

Tutti

7

pro - pter ma - gr - - - am tu - - - am, pro - pter ma - gnam

pro - pter - - - nam glo - ri-am tu - am, pro - pter ma - gnam

am glo - ri - am tu - - - nam

, ma-gnam glo - ri - am tu - - - nam

+Tr

10 **Vivace**

glo - ri - am tu - - - am. Do - mi - ne De - - us, Rex coe - le -

glo - - ri - am tu - am. Do - mi - ne De -

glo - ri - am tu - - - am. Do - - mi - ne De - us, Rex coe -

glo - ri - am tu - - - am. Do - mi - ne De - us, Rex coe - le -

Archi

13

stis, De - us Pa - - ter o - mni - pot -

us, De - us Pa - ter o - mni

le - - - stis, De - us Pa - ter o - mni

stis, De - us Pa - ter, Pa - ter c Do - mi - ne Fi -

16

Fi - li u - ni - ge - - ste. Do - mi - ne De - us, A - gnus De - i, Do - mi - ne

- mi - ne Fi - l. - - su Chri - ste. Do - mi - ne De - us, A - gnus

- - su Chri - ste.

- - te, Je - su Chri - - ste.

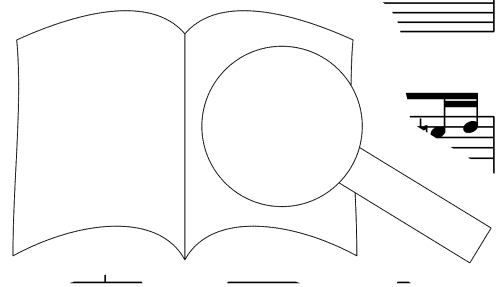

PROBEN  
Ausgabequalität gegenüber Original evtl. gemindert • Evaluation Copy - Quality may be reduced • Carus-Verlag

19

De - us, A - gnus De - i, Fi - li - us Pa - tris, A - gnus De - i, Do - mi - ne De - us, A - gnus De - i, Fi -

De - i, Fi - li - us Pa - - - - tris, Do - mi - ne De - - - us, A - gnus De - i, Fi -

Do - mi - ne De - us, A - gnus De - i, Do - mi - ne De - us, A - gnus De - i,

Do - mi - ne De - us, A - gnus De - i, Do - mi - ne De - us, A - gnus De - i, A - gnus De - i,

22

- li - us Pa - tris, Fi - li - us Pa - - - tris.

- li - us Pa - tris, Fi - li - us Pa - - - tris. di pec -

Fi - li - us Pa - tris, Fi - li - us, Fi - li - us Pa - - - tris. - lis pec -

Fi - li - us Pa - tris, Fi - li - us Pa - - - tris. tol - lis pec -

26

ca - ta, pec - ca - ta

ca - ta, pec

ca -

mi - se - re - re, re,

i - di,

Solo

Archi

*p*

30

Solo

Solo

mi - se - re - re, mi - se - re - re,

mi - se - re - re, mi - se - re - re,

mi - se - re - re, mi - se - re - re,

*fp* *fp*

33

Tutti

Tutti

Tutti

Tutti

mi - se - re - re, mi - se - re - re, mi - se - re - re,

mi - se - re - re, mi - se - re - re - no

mi - se - re - re, mi - re - re - re, re.

Tr, Cor *p* Archi *f*

37 **Vivace**

bis. Qui

bis.

bis

qui tol - lis pec - ca - ta mun - - di,

qui tol - lis pec - ca - ta mun - - di,

pec ca - ta,

tol - lis pec ca - ta, pec

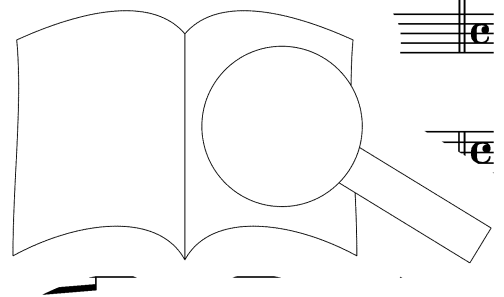

42 Adagio

sus - ci-pe, sus - ci-pe de-pre-ca-ti-o-nem, sus - ci-pe, sus - ci-pe de-pre-ca-ti-o-nem,

Archi  
p

46

de - pre-ca-ti-o-nem no - - - stram,

Solo  
sus -  
Solo  
sus

49

- ci-pe de-pre-ca-ti-o - - -  
as - - - ci-pe de-pre-ca-ti-o - - -  
ci-pe, sus - ci-pe de-pre-ca-ti -  
sus - - - ci-pe

Tutti  
Solo  
fp

52 **Vivace**

- - nem no - - - - stram. Qui se - des ad -  
 - - nem no - - - - stram. Qui se - des ad  
 o - nem no - - - - stram. Qui se - des ad  
 de-pre-ca-ti - o-nem no - stram. Qui se - des ad

56 **Adagio**

dex - te - ram Pa - tris, Solo  
 dex - te - ram Pa - tris, mi - se - re - re, re - re,  
 dex - te - ram Pa - tris,  
 dex - te - ram Pa - tris,

60

mi - se - re - re, mi - se - re - re, mi - se -

PROBEPARTITUR  
 Ausgabqualität gegenüber Original evtl. gemindert • Evaluation Copy - Quality may be reduced • Carus-Verlag

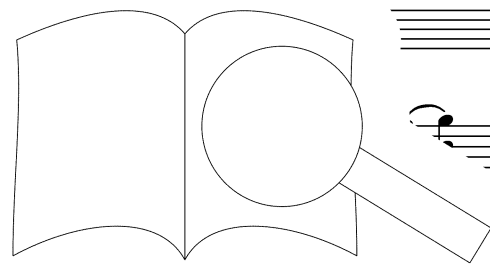

63

Solo

mi - se - re - re,  
 re - - - re, mi - se - re - re,  
 Solo  
 mi - se - re - re,  
 Solo  
 mi - se - re - re,

*f* *fp* *fp*

66

Tutti

mi - se - re - re, mi - se - re -  
 Tutti  
 mi - se - re - - - re, mi - se -  
 Tutti  
 mi - se - re - re, mi - se - re -  
 Tutti  
 mi - - - se - - - re - - - re

*f*

69

- bis,  
 no - - - bis, mi - se - re - re no - - - bis.  
 se - re - re no - - - bis.  
 mi - bis, mi - se - re - - bis.  
 re - re - - re no

PROBEPARTITUR  
 Ausgabequalität gegenüber Original evtl. gemindert • Evaluation Copy - Quality may be reduced • Carus-Verlag

# 5. Quoniam tu solus Sanctus

**Allegro moderato**

2 Corni  
Archi  
Basso continuo

The musical score is written for 2 Corni, Archi, and Basso continuo. It consists of six systems of music. The first system starts with a dynamic marking of *f*. The second system begins at measure 6. The third system begins at measure 11. The fourth system begins at measure 17. The fifth system begins at measure 23 and includes a dynamic marking of *p* and a trill (*tr*) in the upper staff. The sixth system begins at measure 29 and includes the vocal line for Alto *s* with the lyrics "o - lus, tu - so - lu lus". The piano accompaniment continues below the vocal line. A large watermark "PROBEBE PARTITUR" is overlaid diagonally across the page. A smaller watermark "Evaluation Copy - Quality may be reduced • Carus-Verlag" is also present. At the bottom right, there is a large graphic of an open book.



34

San-ctus, tu so - lus, so - lus San-ctus, tu so - lus, so - lus Do - mi-nus, tu

39

so - - - - - lus Do - mi-nus, tu so - - - - -

44

lus, tu - so - - - - - lus, tu so - - - - - mus, Al -

49

tis - si-mus, tr - - - - - so - lus Al - tis - si-mus, Je - su -

54

tu so - lus, tu su -

59

Chri - *tr* - ste.

64

*p*

69

*p*

74

Quo - ni - am tu - so - lus - San - ctus, tu -

79

San - ctus, tu - so - lus, so - lus -

PROBENPARTI FÜR  
 Ausgabqualität gegenüber Original evtl. gemindert • Evaluation Copy - Quality may be reduced • Carus-Verlag

84

San-ctus, tu so - lus San-ctus, tu so - lus, so - lus Do - mi-nus, tu

89

so - lus, so - - - lus San - ctus, tu

94

so - lus, so - - - lus San ctus, tu

99

so - lus San-ctus Do - mi-nus, tu so - - -

104

- - - lus Al - tis tu

109

so - lus, tu so - lus Al - tis - si - mus, Je - su - Chri - - - ste, tu

114

so - lus, tu so - lus Al - tis - si - mus, Je - su - Chri - - - - -

119

- ste.

125

130

chl auszierung der Fermate / suggestion for ornamentation:

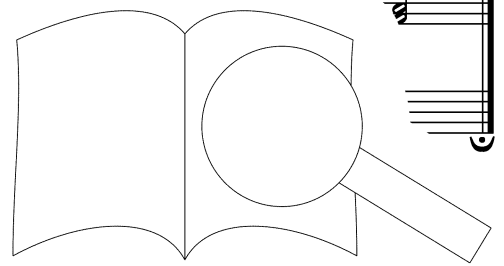

PROBENPARTI FÜR  
 Ausgabqualität gegenüber Original evtl. gemindert • Evaluation Copy - Quality may be reduced • Carus-Verlag

# 6. Cum Sancto Spiritu

Adagio

Soprano

Alto

Tenore

Basso

Cum Sancto, cum Sancto

Cum Sancto, cum Sancto

Cum Sancto, cum Sancto

Cum Sancto, cum Sancto

2 Trombe  
Timpani  
2 Corni  
Archi  
Basso continuo

Tutti

Spi - ri - tu.

Spi - ri - tu.

Spi - ri - tu.

Spi - ri - tu.

Aller

Spi - ri - tu,

e - i Pa - tris. A -

- men, a -

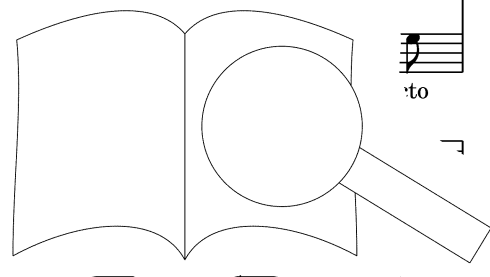

9

men, a - men, a - men.

men, a - men, a - men, a -

Cum San - cto

Spi-ri-tu, in glo - ri-a De - i Pa - tris. A -

13

Cum San-cto Spi - ri - tu, in glo - ri-a De - i Pa-tri-

men.

Spi-ri - tu, in glo - ri-a De - i r

A - cto

16

men, a - men, a - men.

Spi-ri - tu

men, a - men, a - men.

men, a - men, a - men.

cto

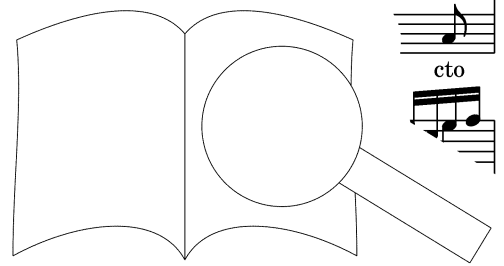

PROBEPARTITUR  
 Ausgabequalität gegenüber Original evtl. gemindert • Evaluation Copy - Quality may be reduced • Carus-Verlag

20

Cum  
men.  
a - men, a - men, a - men,  
Spi - ri - tu, in glo - ri - a De - i Pa - tris. A -

23

San - cto Spi - ri - tu, in glo - ri - a De -  
men, a - men. Cum San - cto Spi - ri -  
a - tris. A -

26

men, a -  
men, a - men, a - men, a -  
Cum San - cto Spi - ri - tu, in glo -  
men, a - men.  
Cum San - i -

30

men, a - men, a - men,

ri-a De - i Pa - tris. A -

Cum San - cto Spi - ri - tu in glo - ri - a,

Pa - - - tris, cum San - cto Spi - ri - tu, in glo -

33

a - - - men.

- - - men, a - - - men,

cum San - cto Spi - ri - tu, in gl

ri-a De - i Pa - - - tris. A - men,

A

37

Spi - ri - tu,

in

a

a - men, a -

e - i Pa - tris. A - men, a - men.

tris. A - - - men, a - men, a - men.

a - men, a -

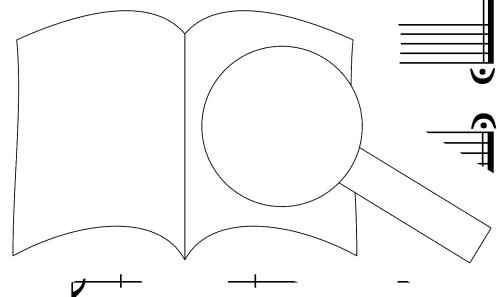

PROBEPARTITUR  
 Evaluation Copy - Quality may be reduced • Carus-Verlag



# Credo

## 7. Credo in unum Deum

**Allegro**

**Tutti**

2 Trombe  
Timpani  
2 Corni  
Archi  
Basso continuo

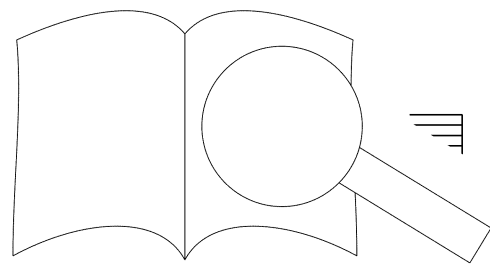

13

Cre - do in u - num De - um, Pa - trem o - mni - pot - en - tem,

Cre - do in u - num De - um, Pa - trem o - mni - pot - en - tem,

Cre - do in u - num De - um, Pa - trem o - mni - pot -

Cre - do in u - num De - um, Pa - trem o - mni - pot -

15

cre - do in u - num De - um,

cre - do, cre - do in u - num De - um, Pa - trem o - mni - pot -

en - tem, cre - do, cre - do in u - num De - um, Pa - trem o - mni - pot -

en - tem, cre - do in u - num De - um, Pa - trem o - mni - pot -

17

en - tem, Je - li et ter - rae, coe - li et ter - rae,

en - tem, in coe - li et ter - rae, coe - li et ter - rae,

en - tem, fa - cto - rem coe - li et ter - rae, coe - li et ter - rae,

fa - cto - rem coe - li et

PROBENPARTITUR  
 Ausgabequalität gegenüber Original evtl. gemindert • Evaluation Copy - Quality may be reduced • Carus-Verlag

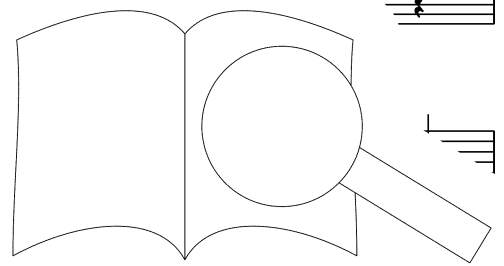

19

vi - si - bi - li - um o - mni - um, et

vi - si - bi - li - um o - mni - um, et in - vi - si - bi - li - um,

vi - si - bi - li - um o - mni - um, vi - si - bi - li - um o - mni - um,

vi - si - bi - li - um o - mni - um, vi - si - bi - li - um o - mni - um,

21

in - vi - si - bi - li - um, vi - si - bi - li - um,

et in - vi - si - bi - li - um, vi - si - bi - li - um,

et in - vi - si - bi - li - um, vi - si - bi - li - um,

et in - vi - si - bi - li - um, vi - si - bi - li - um,

23

vi - si - bi - li - um,

vi - si - bi - li - um,

um si - bi - li - um,

vi - si - bi - li - um,

PROBENPARTITUR

Ausgabequalität gegenüber Original evtl. gemindert • Evaluation Copy - Quality may be reduced • Carus-Verlag

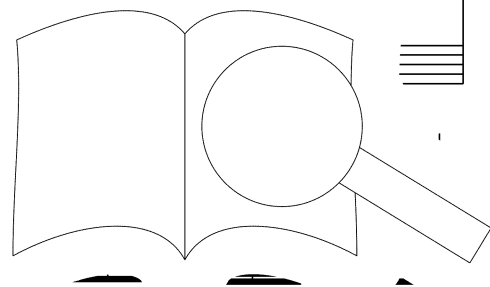

25

vi - - - si - bi - li - um o - - - mni - um,

vi - - - si - bi - li - um o - - - mni - um,

vi - - - si - bi - li - um o - - - mni - um,

vi - - - si - bi - li - um o - - - mni - um,

27

et in - vi - si - bi - li - um, in - vi - si - bi - li -

et in - vi - si - bi - - - li - um, in - vi - si - bi - li -

et in - vi - si - bi - - - li - um

et in - vi - si - bi - - - li - si - bi - - - li -

29

um.

um.

um

# 8. Et in unum Dominum

Moderato

2 Corni  
Archi  
Basso continuo

Musical score for 2 Corni, Archi, and Basso continuo, measures 1-5. The score is in 3/4 time and B-flat major. The upper staff (Corno) features a melodic line with various articulations and dynamics, including *fp*. The lower staff (Archi/Basso continuo) provides a harmonic accompaniment with chords and moving lines.

Musical score for 2 Corni, Archi, and Basso continuo, measures 6-9. The upper staff continues the melodic line, and the lower staff provides accompaniment. Dynamics include *fp*.

Musical score for 2 Corni, Archi, and Basso continuo, measures 10-14. The upper staff features a more active melodic line with *fp* dynamics. The lower staff continues the accompaniment.

Musical score for 2 Corni, Archi, and Basso continuo, measures 15-19. The upper staff includes a trill (*tr*) and *fp* dynamics. The lower staff provides accompaniment.

Musical score for Tenore solo and 2 Corni, Archi, and Basso continuo, measures 20-24. The Tenore solo part begins with the lyrics: "Et in unum, Jo - mi - num, in u - num". The instrumental parts continue with accompaniment. Dynamics include *p*.

Musical score for Tenore solo and 2 Corni, Archi, and Basso continuo, measures 25-28. The Tenore solo part continues with the lyrics: "sum Chri - stum, Je sum". The instrumental parts provide accompaniment.

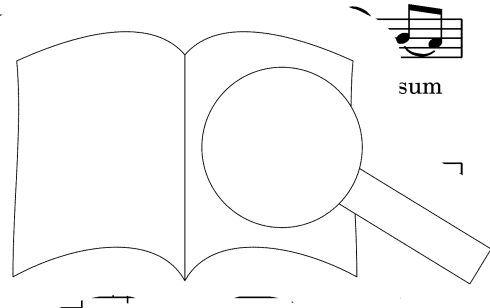

31

Chri-stum, Fi-li-um De-

36

- - - i - u - ni - ge - ni - tum,

40

u - ni - ge - - - ni - tum. - - - tre,

44

ex Pa - tre an - - - te,

49

sae - - -

54

De - um de - De - o, lu - men de -

59

lu - mi-ne, De - um ve - rum de De - o - ve - ro. Ge - ni - tum, non

65

fa - ctum, non fa - ctum, ge - ni - tum, non fa -

70

con - sub - stan - ti - a - l. - tri: per quem o - mni - a

76

- cta sunt, per quem o

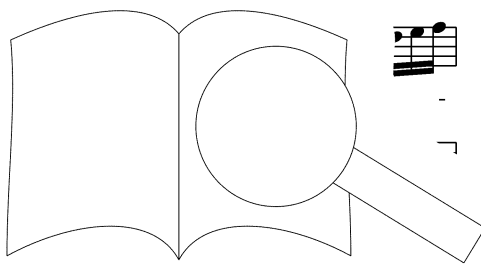

81

- - - - - cta sunt, per quem o - mni-a fa - cta sunt. Qui - pro - pter nos

86

ho - mi-nes, et pro-pter no - stram sa - lu - tem de - scen -

91

- - - - - dit de coe-lis,

96

- - - - - dit de coe -

101

...e Auszierung der Fermate / suggestion for ornamentation:

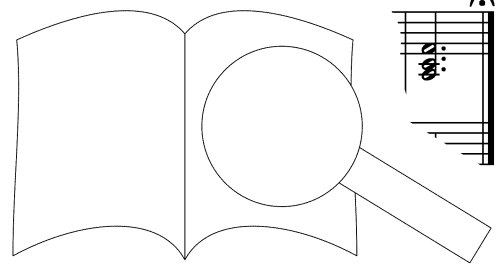





# 10. Crucifixus

Adagio

Archi

tr 3

Tr, Timp con Sord.

2 Trombe  
Timpani  
Archi  
Basso continuo

5 Soprano solo

Alto solo

Basso solo

Cru

us  
fi - xus

8

et - i -

et - i - am pro no - bis:

et

ois,

et - i - am pro no - bis:

no - bis,

et

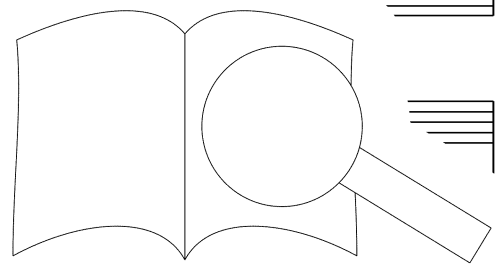

PROBEPARTITUR  
Ausgabequalität gegenüber Original evtl. gemindert • Evaluation Copy - Quality may be reduced • Carus-Verlag

10

sub Pon - ti-o Pi - la - - to pas - - -

sub Pon - ti - o - - - Pi - la - to pas - - - sus,

sub Pon - ti-o Pi - la - - to pas - - - -

13

- - - - - sus, pas - -

pas - - - - sus, pas -

sus, - - - - - us,

*fp* *fp*

15

pas - - - -

pas - - - - sus

pas -

*fp* *p*

PROBE-PARTITUR

Ausgabequalität gegenüber Original evtl. gemindert • Evaluation Copy - Quality may be reduced • Carus-Verlag

17

sus et se - pul - - - tus est,

et se - - pul - - - tus est,

et se - - pul - - - tus est,

19

pas - - - sus et se - pul - -

pas - - - sus et se - pul - - tus

pas - - - sus et se - pul - - tus

21

est.

est.

*decrecendo sempre*

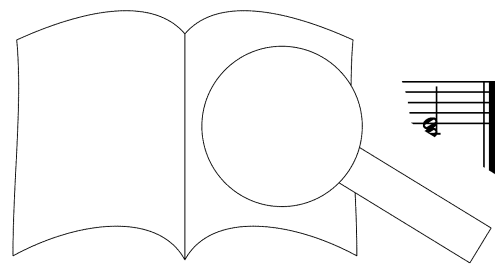

PROBEPARTITUR

Evaluation Copy - Quality may be reduced • Carus-Verlag

Ausgabequalität gegenüber Original evtl. gemindert •

# 11. Et resurrexit

**Allegro**

Tenore *Solo*

Et re-sur-re - - - - - xit ter-ti-a

Archi, Cor

2 Trombe  
Timpani  
2 Corni  
Archi  
Basso continuo

4

Et re - sur - re - xit ter - ti - a di - e, et re - sur - re - xit

Et re - sur - re - xit ter - ti - a di - e, et re - sur -

*Tutti*

di - e, et re - sur - re - xit ter - ti - a di - e, et re - it - - a

Et re - sur - re - xit ter - ti - a di - e, et re - s - - - - - ter - ti - a

*Tutti*

6

di - e, se - cun - - - - - Et a - scen - - - - -

di - e, sr - - - - - ras. Et a - scen - - - - -

di - e, - - - - - dum Scri - ptu - ras. Et a - scen - dit in coe -

- - - - - ptu - - - - - ras.



18 **Adagio** **Allegro**

vi - vos et mor - tu - os: cu - jus re - gni non e - rit fi - nis, cu - jus re - gni

vi - vos et mor - tu - os:

vi - vos et mor - tu - os: cu - jus re - gni non e - rit fi - nis, cu - jus

vi - vos et mor - tu - os:

23

non e - rit fi - - - nis, non e - rit fi - nis, non e -

re - gni non e - rit fi - nis, non e - rit

cu - jus re - rit

re - rit

cu - jus re - rit

fi - nis,

26

non e - rit fi

fi - nis,

fi - nis,

non e - rit fi - nis, non e - rit fi - nis, non,

non e - rit fi - - - nis, non,

ri - rit fi - nis, non e - rit non,

gni non e - rit fi

PROBEPARTITUR

Ausgabequalität gegenüber Original evtl. gemindert • Evaluation Copy - Quality may be reduced • Carus-Verlag

29

non, non, non, non, non, non, non

non, non, non, non, non, non, non

non, non, non, non, non, non, non

non, non, non, non, non, non, non

32

e - rit fi - nis, non, non, non e - - rit fi -

e - rit fi - nis, non, non, non e - rit fi -

e - rit fi - nis, non, non, non e - rit f

e - rit fi - nis, non, non, non

Tr solo

35



41 Basso solo

Et in Spi - ri - tum Sanctum,  
Bc

44

Do - - - - - mi - num, et vi - vi - fi - can - tem, et vi - vi - - fi -

47

can - tem: qui ex Pa - tre Fi - li - o - que pro - ce - -

50

Qui cum

53

si - mul ad - o - ra - tur, et con - glc  
tus

57

est, qui lo - cu - tus est per Pro - phe -

60

tas, per Pro - phe

63

tas.

VI solo

67

71

Sopranc

Et u - nam san - - - li -

75

cam <sup>tr</sup> Ec-cle - si - am. Con - fi - te - or u - num ba - ptis - - ma in re - mis - si -

79

o - nem pec - ca - to - rum, con - fi - te - or u - num, u - num ba - ptis - ma

83

mis - si - o - nem pec - ca - to - - - -

87

91

ng szierung der Fermate / suggestion for ornamentation:

- rum

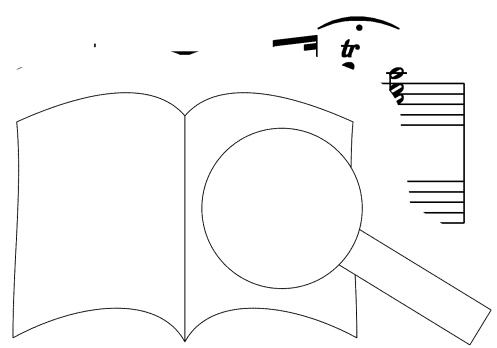

95 **Tutti**

Et ex - spe - - - - - cto, et ex - spe - - - - - cto,

Et ex - spe-cto, et ex - spe-cto, et ex - spe-cto, et ex - spe-cto,

Et ex - spe-cto, et ex - spe-cto, et ex - spe-cto, et ex - spe-cto,

**Tutti**

Et ex - spe-cto, et ex - spe-cto, et ex - spe-cto, et ex - spe-cto,

99

et ex - spe - - - - - cto re - sur-re-cti-o-nem, re -

et ex - spe-cto, et ex - spe-cto re-sur-re-cti-o-nem

et ex - spe-cto, et ex - spe-cto re-sur-re-ct re - o - nem,

et ex - spe-cto, et ex - spe-cto re - sur-re - -

103 **Adagio**

re - - - - - nem mor - tu - o - - - - - rum.

- o - nem mor - tu - o - rum.

re - - - - - nem mor - tu - o - rum.

- - - - - cti - o - nem

rum.

m.

*p*

# 12. Et vitam venturi saeculi

Soprano  
Alto  
Tenore  
Basso

Et vi - tam ven - tu - ri sae - cu - li. A - men,

Et

2 Trombe  
Timpani  
2 Corni  
Archi  
Basso continuo

Archi

7

a - - - - men, a - - - -

vi - - - - tam ven - tu - ri sae - cu - li. A - m

+Cor

12

- - - - me - cu - ri sae - - cu - li.

a - - - - - - - - men, a -

vi - - - - ri sae - cu - li. A -

17

Et

men, et vi - tam ven - tu - ri - sae - cu - li,

a - - - men, a - - -

vi - - - tam ven - tu - ri sae - - - cu - li. A - - - men,

22

vi - - - tam ven - tu - ri sae - - - cu - li. A -

- - - men. Et vi - tam ven - tu - ri sae - - - cu - li. A - men,

a - - - men, a - - - men.

27

a - - - men.

vi - - - ri sae - - - cu - li. A - - - men. Et

PROBEPARTITUR  
 Ausgabequalität gegenüber Original evtl. gemindert • Evaluation Copy - Quality may be reduced • Carus-Verlag

32

Et vi - - -

vi - tam ven - tu - ri sae - cu - li. A - men, a - - - men.

men, a - - - - - men,

tam ven - tu - ri sae - cu - li. A - - - - - men.

37

tam ven - tu - ri sae - - - - - cu - li. A - -

Et vi - - - tam v

a - - - - men, a - - - - - men,

Et

42

A -

a

Et vi - -

a - - - - - men, a - - - -

vi - tam ven - tu - ri

m ven - tu - ri sae - cu - l

47

tam ven - tu - ri sae - - - cu - li, et

- - - men. Et vi -

A - - - - - men.

Et vi - - - - tam ven - tu - ri sae - cu - li.

52

vi - tam ven - tu - ri sae - cu - li. A -

tam ven - tu - ri sae - cu - li. A -

Et vi - - - - sae - - -

A - - - - men,

57

men, a - - - - - men, a - - - - - men.

men, - - - - - men, a - - - - - men.

a - - - - - men, a - - - - -

a - - - - -



# Sanctus

## 13. Sanctus

**Adagio**

Soprano

Alto

Tenore

Basso

2 Trombe

Timpani

2 Corni

Archi

Basso continuo

San-ctus, San - ctus, San-ctus, San - ctus, San - - - ctus, San -

San - ctus, San - ctus, San - - - ctus, San -

San - ctus, San - ctus, San - ctus, San -

San - ctus, San - ctus, San - ctus, San -

*Tutti*  
*f*

San - - - ctus, San - - - ctus Do-mi-nus D

San - ctus, San - ctus, San - - - ctus Do-mi

San - ctus, San - ctus, San - ctus

San - ctus, San - ctus, Do-mi-nus De-us Sa - ba -

San - ctus, San - ctus, Do-mi-nus De-us Sa - ba -

**Allegro**

oth. *P* er - ra, ple - ni sunt coe - li et ter - ra

oth. i et ter - ra, ple - ni sunt coe - li et ter - ra

oth. t coe - li et ter - ra,

ni sunt coe - li et ter - ra,

15 *ossia:* *ossia:*

glo - ri - a, glo - ri - a, glo - ri - a,  
 glo - ri - a, glo - ri - a, glo - ri - a,  
 glo - ri - a, glo - ri - a, glo - ri - a,  
 glo - ri - a, glo - ri - a, glo - ri - a

20

glo - ri - a, glo - ri - a, glo - ri - a  
 - ri - a, glo - ri - a, in ex -  
 glo - ri - a, glo - ri - a, glo - ri - a  
 - ri - a, glo - ri - a, a. O - san - na in ex -  
 a. O - san - na in ex -

25

cel - sis, in ex - cel - sis, o - san - na, o -  
 cel - sis, an - na in ex - cel - sis, o - san - na,  
 o - san - na in ex - cel - sis, o -  
 o - san - na in ex - cel - sis, an - na,

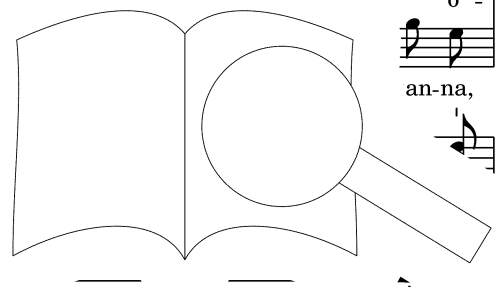

PROBENPARTITUR  
 Ausgabegüte gegenüber Original evtl. gemindert • Evaluation Copy - Quality may be reduced • Carus-Verlag

29

san-na, o-san-na in ex-cel - sis, o-san-na, o-san-na, o-san-na in ex-cel - sis.  
 o-san-na in ex-cel - sis, o-san-na, o-san-na in ex-cel - sis.  
 san-na, o-san-na in ex-cel - sis, o-san-na, o-san-na, o-san-na in ex-cel - sis.  
 o-san-na in ex-cel - sis, o-san-na, o-san-na in ex-cel - sis.

#### 14. Benedictus

Archi

Flauto  
(o Violino solo)  
Archi  
Basso continuo

Fl *p*

6

Archi

12

Fl *p*

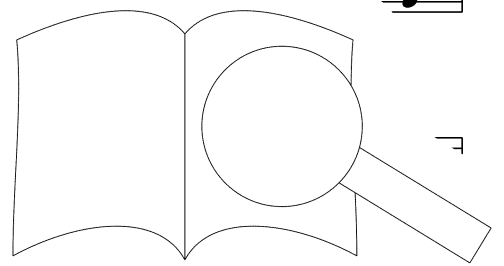

21

3 3

tr.

3 3

26 Soprano solo

Be - ne - di - ctus,

f

p

32

be - - ne - di-ctus, be - ne - di-ctus qui

f

p

38

- nit in no - mi-ne Do

p

f

43

Be - - - ne -

f

48

be - - ne - - di - - ctus qui ve - nit in no - mi - ne

Archi

53

Do - mi - ni. Be - ne - di - - ctus, be - ne - di - -

59

ctus qui ve - nit, qui ve - nit in no

Fl

64

- - - mi - ne Do - mi - ni.

69

be - ne - di - ctus,

qui

75

ve - nit in no - mi - ne Do - mi -

81

ni.

86

91

be - ne - di - ctus,

97

be - ve - no - mi -

\* Auszeichnung der Fermate / suggestion for ornamentation:

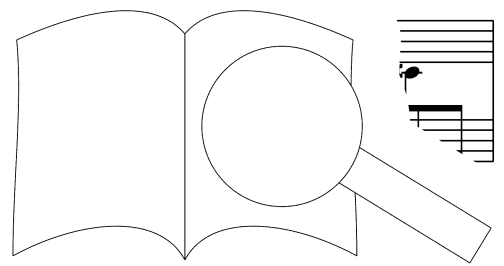

103

ni. Archi Be - ne - di - ctus, be - ne - di - ctus,

109

be - ne - di - ctus qui ve - - - nit in no - mi - ne

115

Do - mi - ni. Be - ne - di - ctus, be - ctus - nit in

122

no - - - mi - ne Do - mi - ni,

127

be - ne - di - ctus, qui

133

ve - nit in no - mi - ne Do - mi - ni, qui ve - nit in no - mi - - ne

140

Do - - mi - ni.

Archi

146

151

155

chl- auszierung der Fermate / suggestion for ornamentation:

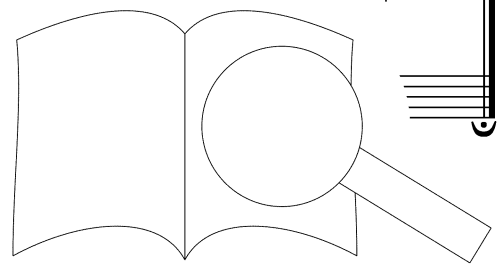

PROBENPARTITUR  
 Ausgabqualität gegenüber Original evtl. gemindert • Evaluation Copy - Quality may be reduced • Carus-Verlag



# 15. Hosanna

Allegro

Soprano

Alto

Tenore

Basso

2 Trombe

Timpani

2 Corni

Archi

Basso continuo

16. Agnus Dei

Adagio

2 Trombe  
Timpani  
2 Corni  
Archi  
Basso continuo

Archi

*p* *cresc.* *più f* *f*

*p* *cresc.* *f* *ff* *f*

7 Alto solo

A -

*p*

10

tol-lis pec-ca - ta mun-di: mi - se mi - se-re - re - no-bis, mi - se -

*fp* *p*

13

re - re - no - bis,

*3* *3*

~ Ausführung / performance suggestion:

mun - di:

16 Soprano solo

mi-se-re-re no-bis, mi-se-re-re no-bis, mi-se-re-re no-bis.

Alto solo

Tenore solo

mi-se-re-re no-bis, mi-se-re-re no-bis, mi -

19 Alto solo

mi-se-re-re no-bis, mi-se-re-re no-bis.

Tenore solo

se-re-re no-bis, mi-se-re-re no-bis.

*fp* *p* *Bc*

23 Soprano solo

A

tol-lis pec-ca-ta mun-di:

*fp*

26

mi-se-re se-re-re no-bis, mi-se-re-

Ausgabequalität gegenüber Original evtl. gemindert • Evaluation Copy - Quality may be reduced • Carus-Verlag

*mf* Führung / performance suggestion:

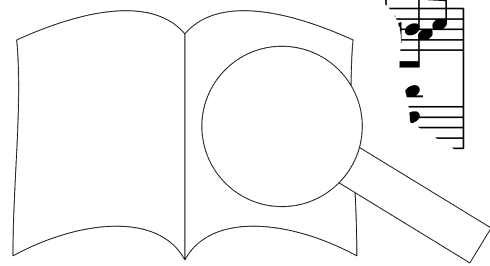

29

re no - bis.

mi-se-re-re no-bis, mi-se-re-re no-bis,

mi-se-re-re no-bis, mi-se-re-re no-bis,

33

mi-se-re - - re no - bis.

mi-se-re - - re no - bis.

qui

qui

qui

Tutti

A

Tutti

A

36

tol-lis pec-ca-ta mun-di,

tol-lis pec-ca-ta

tol-lis p

qui tol-lis pec-ca - - ta mun-di:

- di, qui tol-lis pec-ca - - ta mun-di:

- ta mun - di, qui tol-lis pec-ca - - ta mun-di:

pec-ca-ta mun - di, qui

i:

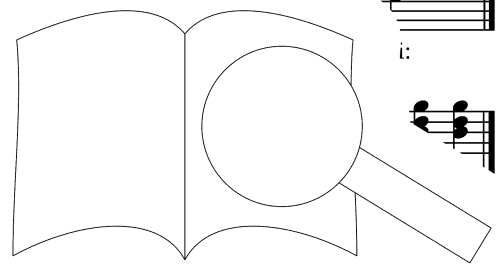

# 17. Dona nobis pacem

Allegro

Soprano

Alto

Tenore

Basso

2 Trombe

Timpani

2 Corni

Archi

Basso continuo

8

Solo Tutti

Do - na no-bis pa - cem, pa - cem, do - na no - bis pa - cem.

pa - cem, do - na no-bis pa - cem, do - na no-bis do -

pa - cem, do - na

pa - cem, do - na

Tutti

do - na



14

na no -

- na no-bis pa - cem, pa - cem, pa - cem,

na - cem, pa - cem, pa - cem,

na - bis pa - cem, pa - cem, pa - cem,

na no - - - bis

tr tr



20

pa-cem,

pa-cem,

pa-cem, do-na no - bis pa-cem, pa - cem, do - na no - bis pa-cem,

pa-cem,

Bc

28

pa-cem, pa-cem, do -

pa-cem, pa-cem,

pa-cem, do - na no-bis pa-cem, do - na no-bis pa-cem, do - na

do - na no-bis pa-cem, do - na r - - na

Tutti

Solo

Tutti

Solo

Tutti

35

no - - - bis

no - - - cem, do - na no-bis pa-cem,

no - - - cem, do - na no-bis pa-cem, do - na no-bis

no pa - - - cem, do - na no-bis

pa - - - cem,

pa - - - cem,

Solo

Tutti

Solo

Tutti

Solo

42

pa-cem, Tutti Solo  
pa-cem, do - na no - bis pa - cem, pa - cem, do - na no - bis  
pa-cem,  
pa-cem,

Bc  
p

49

Solo Tutti Solo Tutti  
do - na no - bis pa-cem, do - na no - bis  
pa-cem, pa-cem, do - na no - bis pa-cem, do - na  
pa-cem,  
pa-cem,

Tutti

56

na no do - - - na no - - -  
na do - - - na no - - -  
na bis, do - - -  
- - bis, do - -

Ausgabequalität gegenüber Original evtl. gemindert • Evaluation Copy - Quality may be reduced • Carus-Verlag

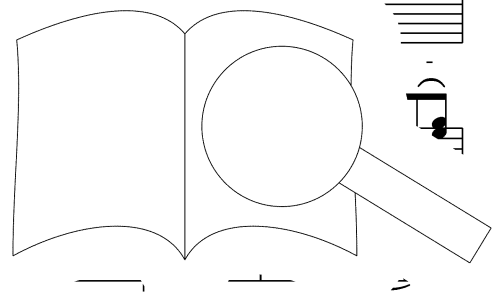

62

bis pa - - - cem, do - na no-bis pa -

bis pa - - - cem, do - - - na no - - bis

bis pa - - - cem, do - - - na no - -

bis pa - - - cem, do - na no - bis, do - na

68

- - - cem, pa - cem, do - na pa-cem

pa - - - cem, pa - cem, do - na na no -

- bis, no - bis pa - cem, do - r ce - - na no -

no - bis, do - na pa - cem, do - - na no -

74

- bis pa - do - - na no - bis pa - cem.

bis pa - - - bis, do - - na no - bis pa - cem.

bis no - bis, do - - cem.

do - na no - bis, do - m.

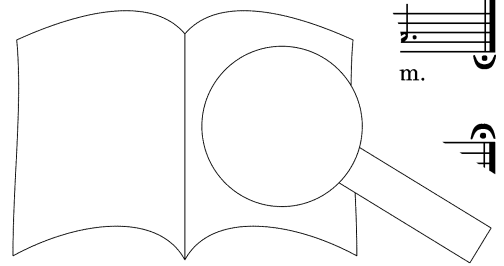

PROBEPARTITUR  
 Ausgabqualität gegenüber Original evtl. gemindert • Evaluation Copy - Quality may be reduced • Carus-Verlag