

Requiem

KV 626

Wolfgang Amadeus Mozart (1756–1791)

ergänzt und herausgegeben von

completed and edited by

Robert D. Levin

Introitus

1. Requiem aeternam

Adagio

Corno di Bassetto I, II
in Fa/F

Fagotto I, II

Clarino I, II
in Re/D

Timpani
in Re-La/D-A

Trombone alto

Trombone tenore

Trombone basso

Violino I

Violino II

Viola

Soprano

Br

Concello,
Basso, Organo

Solo

p Organo: *tasto solo*

simile

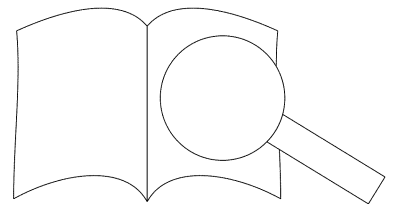

5

Musical notation for the first system, including vocal lines and piano accompaniment. The system starts with a treble clef and a key signature of one sharp (F#). The vocal line features a melodic phrase with a slur. The piano accompaniment includes chords and moving lines in both hands.

Musical notation for the second system, including vocal lines and piano accompaniment. The vocal line continues with a melodic phrase. The piano accompaniment features a prominent bass line with a forte (*f*) dynamic marking.

Musical notation for the third system, including piano accompaniment. The piano part continues with chords and moving lines in both hands, maintaining the forte (*f*) dynamic.

Musical notation for the fourth system, including piano accompaniment. The piano part continues with chords and moving lines in both hands, maintaining the forte (*f*) dynamic.

Musical notation for the fifth system, including piano accompaniment. The piano part continues with chords and moving lines in both hands, maintaining the forte (*f*) dynamic.

Musical notation for the sixth system, including piano accompaniment. The piano part continues with chords and moving lines in both hands, maintaining the forte (*f*) dynamic.

Musical notation for the seventh system, including piano accompaniment. The piano part continues with chords and moving lines in both hands, maintaining the forte (*f*) dynamic.

Musical notation for the eighth system, including piano accompaniment. The piano part continues with chords and moving lines in both hands, maintaining the forte (*f*) dynamic.

Org.

Musical notation for the ninth system, including piano accompaniment. The piano part continues with chords and moving lines in both hands, maintaining the forte (*f*) dynamic.

PROBEKOPPIE
Ausgabequalität gegenüber Original evtl. gemindert • Evaluation Copy - Quality may be reduced • Carus-Verlag

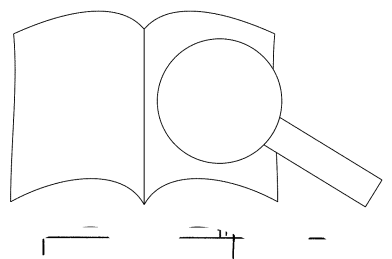

9 *f*

f Tut^o

f Tutti

- ter - - nam do - na e - is

- nam do - na e - is Do - - -

- nam do - na e - is Do - mi-ne,

an, ae - ter - nam do - na e - is, do - na

*) Vgl. Krit. Bericht. / Cf. Critical Commentary

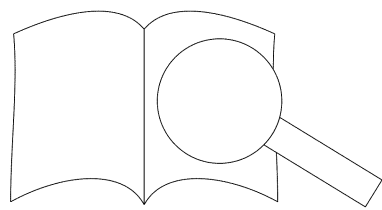
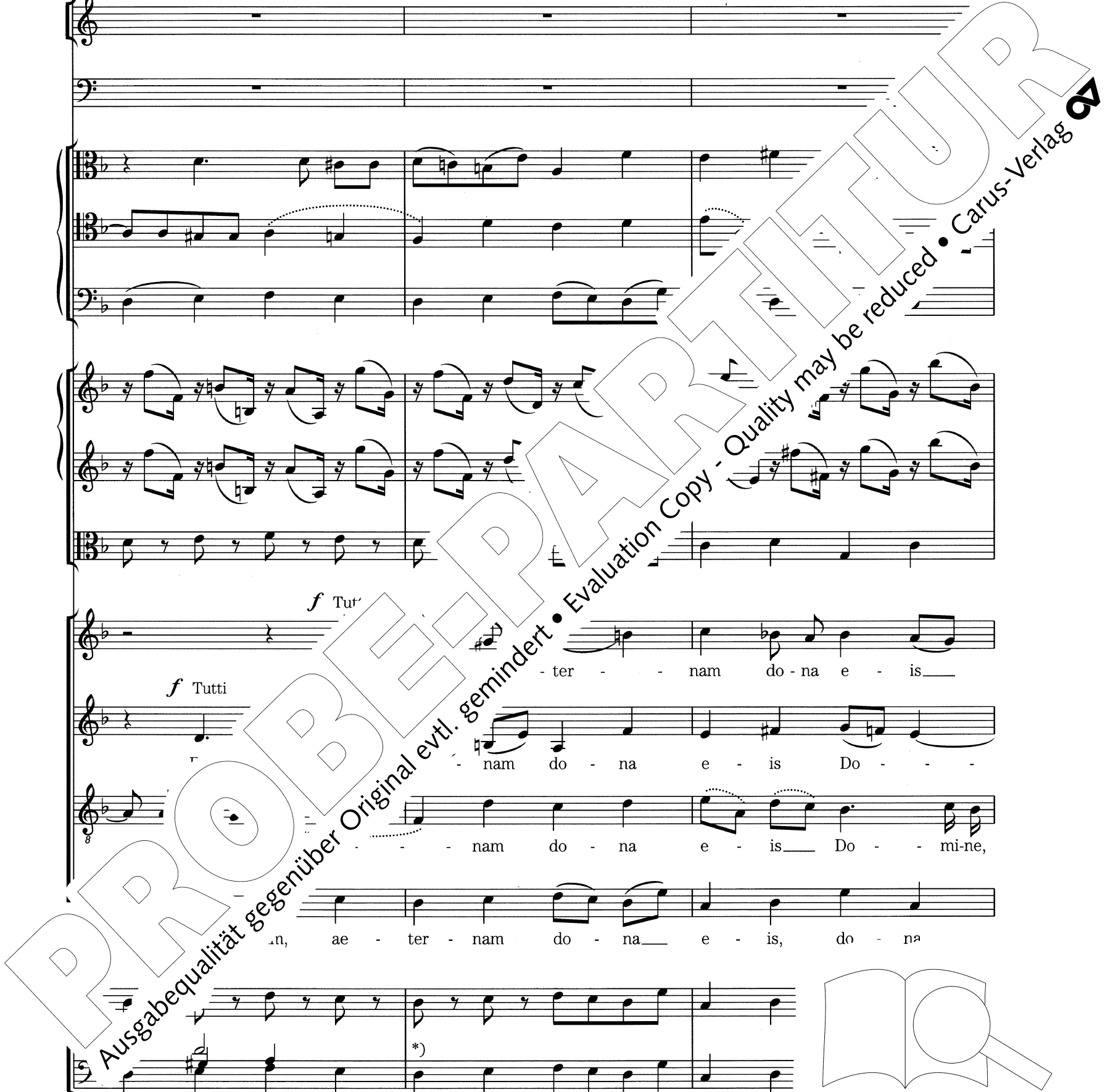

Do - mi - ne, a - e - ter - nam do - na e - is Do - mi - ne:

- - - - is Do - mi - ne, do - na e - is Do - mi - ne:

- - ter - nam do - na e - is Do - mi - ne, e - is Do - mi - ne:

a e - is Do - mi - ne, re - qui - em, a - e - ter - nam do - na e - is

vc./Basso/Organo

7 6 6 6 # #4 6 - 4 - 6 7 8 6 # 6 4 3

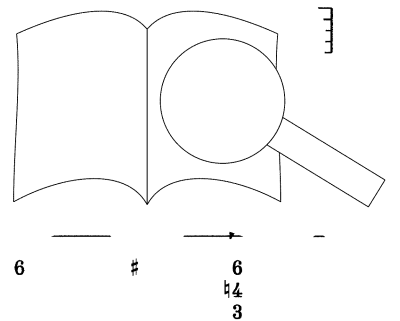

15

Musical notation for the first system, including vocal line and piano accompaniment.

Musical notation for the second system, including vocal line and piano accompaniment.

Musical notation for the third system, including vocal line and piano accompaniment.

Musical notation for the fourth system, including vocal line and piano accompaniment.

Musical notation for the fifth system, including vocal line and piano accompaniment.

Musical notation for the sixth system, including vocal line and piano accompaniment.

Musical notation for the seventh system, including vocal line and piano accompaniment.

Musical notation for the eighth system, including vocal line and piano accompaniment.

PROBEPARTITUR
 Ausgabqualität gegenüber Original evtl. gemindert • Evaluation Copy - Quality may be reduced • Carus-Verlag

et lux per-i,

et lux per-pe - tu-a lu - ce-at,

et lux per-pe - tu-a lu - ce-at,

tu-a, et lux per-pe - tu-a lu - ce-at,

lux per-pe - tu-a, et lux per-pe - tu-a lu - ce-

Organo: *tasto solo*

6
4
3

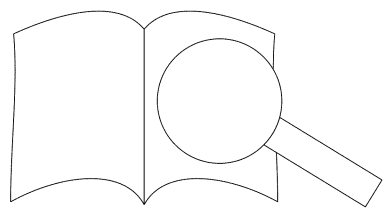

p
senza Organo

ossia: senza Tromboni.....

lu - ce -

- is.

- is.

ce - at e - - - is.

utti Bassi

Solo

Organo: tasto solo

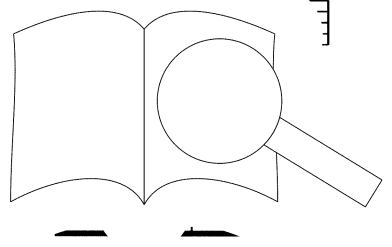

PROBEPARTITUR
 Ausgabequalität gegenüber Original evtl. gemindert • Evaluation Copy - Quality may be reduced • Carus-Verlag

Solo

Te de - us De - us in Si - on,

Violoncelli

senza Organo

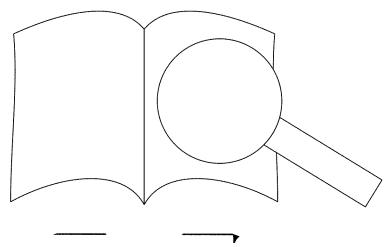

PROBEPARTITUR

Ausgabequalität gegenüber Original evtl. gemindert • Evaluation Copy - Quality may be reduced • Carus-Verlag

First system of musical notation, including vocal line with lyrics "a 2 b." and piano accompaniment. Dynamics include *f*.

Second system of musical notation, including vocal line and piano accompaniment.

Third system of musical notation, including vocal line and piano accompaniment.

Fourth system of musical notation, including vocal line and piano accompaniment. Dynamics include *f*.

Fifth system of musical notation, including vocal line with lyrics "et ti cum in Je - ru - - sa - lem." and piano accompaniment. Dynamics include *f* and *Tutti*.

Sixth system of musical notation, including vocal line with lyrics "Ex - au - di," and piano accompaniment. Dynamics include *f* and *Tutti*.

Seventh system of musical notation, including vocal line with lyrics "Ex - au - di, ex -" and piano accompaniment. Dynamics include *f* and *Tutti*.

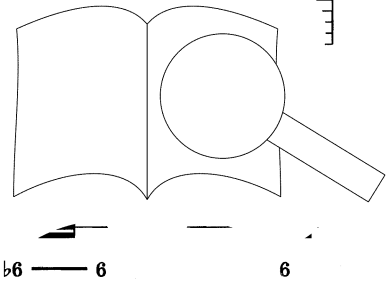

PROBEPARTITUR
 Ausgabqualität gegenüber Original evtl. gemindert • Evaluation Copy - Quality may be reduced • Carus-Verlag

f Tutti

Ex - - - - - di o - ra - ti - o - nem me - -

ex - au - di o - ra - - - ti - o - nem me - -

ex - au - - di o - ra - ti - o - nem me - - - -

di, ex - au - - di, ex - au - di o - ra - ti - o

6 6 #3 6 6 6 4 3

PROBENPAPIER
Ausgabequalität gegenüber Original evtl. gemindert • Evaluation Copy - Quality may be reduced • Carus-Verlag

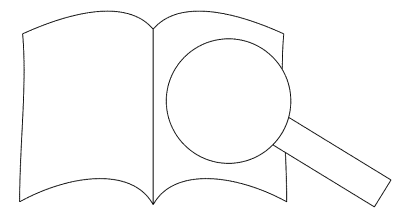

32

p *f*

ossia: col 2^{do}

p *f*

et.

f

Do - na,

f

Re

f

p *f*

Solo *Organo: tasto solo* Tutti

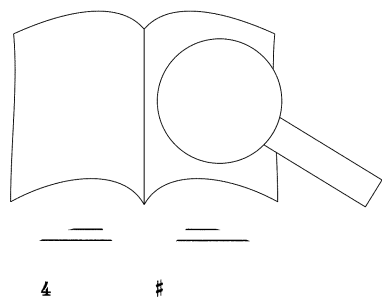

PROBENPARTITUR

Ausgabequalität gegenüber Original evtl. gemindert • Evaluation Copy - Quality may be reduced • Carus-Verlag

f

f

Do - na, do - - na e - - - is -
 - is Do - mi - ne, do - na, do - na e - - is re -

Re - - qui - em ae - ter - - nam
 - - - - - nam do

Violoncelli *Tu*

#6 6 #5/4 # 6 6 5 9 b3 - 6

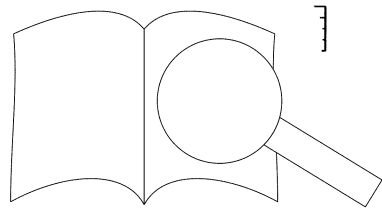

Musical notation for the first system, featuring a vocal line in the upper staff and piano accompaniment in the lower staff. The piano part includes complex rhythmic patterns and arpeggiated chords.

Two empty musical staves, one for the vocal line and one for the piano accompaniment, indicating a section where the music is not present on this page.

Musical notation for the third system, continuing the vocal and piano parts from the first system.

Musical notation for the fourth system, continuing the vocal and piano parts.

Musical notation for the fifth system, continuing the vocal and piano parts.

Do - mi-ne,

- - na_ e - is re - - qui - em ae - ter - -

- - nam, do - na_ e - is_ Do - mi-ne, do - na

- - na_ e - - is_, do - - na_ e - is, do - -

e - is Do - mi-ne, do

Violoncelli

Tutti Bassi

Musical notation for the bottom system, including the vocal line and piano accompaniment.

4 - #3 — 6 5 — 6 [4]6 [4]6 — 4 - 3 — 6 [—] 6 [—]

3 2 —

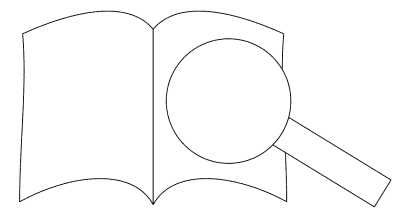

PROBEKOPPIE
Ausgabequalität gegenüber Original evtl. gemindert • Evaluation Copy - Quality may be reduced • Carus-Verlag

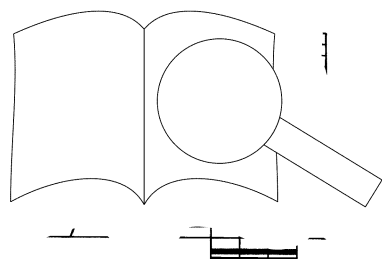

DROBEPAPIER • Evaluation Copy - Quality may be reduced • Carus-Verlag

Ausgabequalität gegenüber Original evtl. gemindert

6 7 6 5 6 5 #3 6 6 7 #6 7 6 5 4 5
 4 4# 3 4# 3 #3 5 3 #3 4# 3#

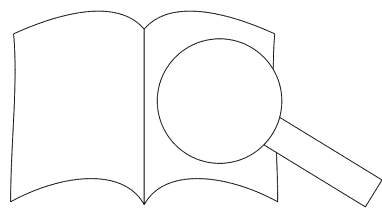

PROBENFÜR

Ausgabequalität gegenüber Original evtl. gemindert • Evaluation Copy - Quality may be reduced • Carus-Verlag

2. Kyrie

49 Allegro

2.f f

f f

f f

le - - - - - i -
Ky - ri -

e - e - le - i - son, e - le - - - - -
Org. f
tasto solo

PROBEPARTITUR
Ausgabequalität gegenüber Original evtl. gemindert • Evaluation Copy - Quality may be reduced • Carus-Verlag

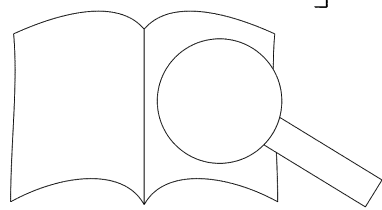

Musical notation for the first system, including vocal line and piano accompaniment. The piano part features a prominent bass line with eighth notes.

Musical notation for the second system, including vocal line and piano accompaniment. The piano part continues with rhythmic accompaniment.

Musical notation for the third system, including vocal line and piano accompaniment. The piano part features a melodic line in the right hand.

Musical notation for the fourth system, including vocal line and piano accompaniment. The piano part continues with rhythmic accompaniment.

Musical notation for the fifth system, including vocal line and piano accompaniment. The piano part features a melodic line in the right hand.

Musical notation for the sixth system, including vocal line and piano accompaniment. The piano part continues with rhythmic accompaniment.

Musical notation for the seventh system, including vocal line and piano accompaniment. The piano part features a melodic line in the right hand.

Musical notation for the eighth system, including vocal line and piano accompaniment. The piano part continues with rhythmic accompaniment.

Musical notation for the ninth system, including vocal line and piano accompaniment. The piano part features a melodic line in the right hand.

PROBEKOPPIE
 Ausgabqualität gegenüber Original evtl. gemindert • Evaluation Copy - Quality may be reduced • Carus-Verlag

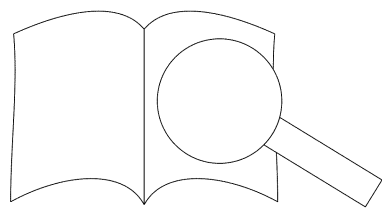

c./Basso/Organo

♯3 ♯3 - 4 7 7 - ♯3 7 - 6 - 6 -
 ♯2 ♯

#3 7 6 b3 4 #6 6 6 #4 [6] 6 6 - 6 #4 6 #5 #6
 [4] 5 2 5 5 4 2 [4] 5 - 4 2

PROBE PAPIER
 Ausgabegüte gegenüber Original evtl. gemindert • Evaluation Copy - Quality may be reduced • Carus-Verlag

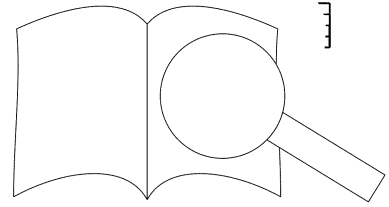

e - le - - - i - son, e - le - i -
 - i - son, e - le - - -
 - - son, e - le - - - i - son, e - le

6 9 48 7[4]5 3 6 8 7 6 6 45 #4 6 #6
 7 6 5 #3 3 4 3 3 2 #4 #3
 3 - - - - -

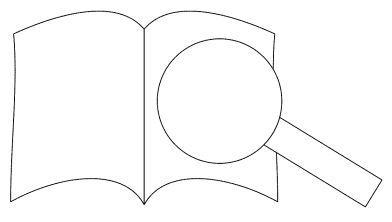

PROBEPAPIER
 Ausgabqualität gegenüber Original evtl. gemindert • Evaluation Copy - Quality may be reduced • Carus-Verlag

First system of musical notation, featuring vocal lines and piano accompaniment.

Second system of musical notation, consisting of empty staves.

Third system of musical notation, including piano accompaniment.

Fourth system of musical notation, including piano accompaniment.

Vocal lines with lyrics: Ky - ri - e e - le - - i - le - - i - son, Ky - ri - i - son, e - le -

Bottom system of musical notation, including parts for Tutti Bassi, Violoncelli, and Vic.

Diagram of a book and a magnifying glass, likely a logo or watermark.

PROBEKOPPIERUNG
 Ausgabqualität gegenüber Original evtl. gemindert • Evaluation Copy - Quality may be reduced • Carus-Verlag

Musical notation for the first system, featuring a vocal line in the upper staff and piano accompaniment in the lower staff. The key signature has one flat (B-flat), and the time signature is 4/4. The piano part consists of a steady eighth-note accompaniment.

Two empty musical staves, one for the vocal line and one for the piano accompaniment, indicating a section where the music is not present on this page.

Musical notation for the third system, continuing the vocal line and piano accompaniment from the first system. The piano part continues with the same eighth-note accompaniment.

Musical notation for the fourth system, continuing the vocal line and piano accompaniment. The piano part continues with the same eighth-note accompaniment.

Musical notation for the fifth system, continuing the vocal line and piano accompaniment. The piano part continues with the same eighth-note accompaniment.

son, a la - - - i-son, Chri-ste e-lei - -
 e-le - - - i-son, Chri-ste e-le - -
 son, Ky - ri - e e - le - i-son, e -

Musical notation for the sixth system, continuing the vocal line and piano accompaniment. The piano part continues with the same eighth-note accompaniment.

5 6 6 6 6 7 #6 #3 #4 5 [-]6[3 -]b3 [-] [8] b9 8 7 b6
 5 5 5 2 3 [-]4 #3

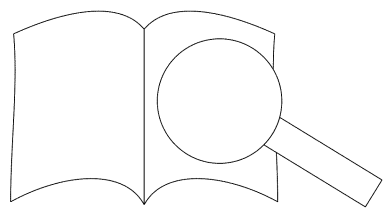

PROBE
 Ausgabequalität gegenüber Original evtl. gemindert • Evaluation Copy - Quality may be reduced • Carus-Verlag

son,

i - son, Chri - ste e -

Ky - ri - e e

Tutti Bassi

6 — 5 [—] b3 [—] #3 #4 6 6 3 b9 8 — 6 6 5 6 [-] 5
 7 [b]6 5 7 4 [4]3
 ossia: 5 [-] 6 5

PROBENPAKUNGSZWECK
 Ausgabequalität gegenüber Original evtl. gemindert • Evaluation Copy - Quality may be reduced • Carus-Verlag

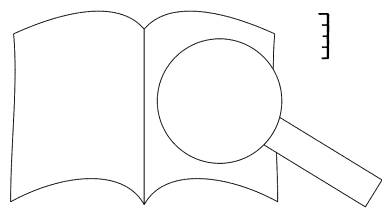

Musical notation for the first system, featuring a vocal line and piano accompaniment.

Empty musical staves for the second system.

Musical notation for the third system, including piano accompaniment.

Musical notation for the fourth system, including piano accompaniment.

son, i - son, e - le - i - i - son,

i - son, Christe e - le -

Ky - ri - e e - le - i - son,

Tutti Bassi

Musical notation for the fifth system, labeled "Tutti Bassi".

7 $\flat 6$ 6 $\flat 6$ 6 $\flat 5$ 7 $\flat 3$ 6 $\left[\begin{array}{c} \text{---} \\ \text{---} \end{array} \right]$

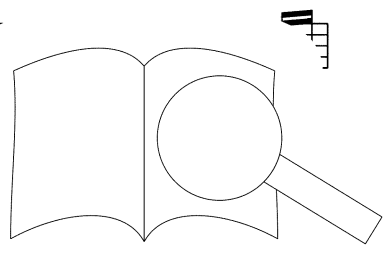

PROBEKOPPIE
 Ausgabqualität gegenüber Original evtl. gemindert • Evaluation Copy - Quality may be reduced • Carus-Verlag

son, e - le

e - le - - - i - -

e e - le - - i - son,

i - son, e - le - i - son,

Chri - ste e -

- - i - son,

Chri - ste e - le - - -

Violoncelli

Tutti Bassi

6 [—] 46 4 6 [-] b6 5 b3 b3 - 43 [3 —] 6 [b]6 5 6 6 6 4

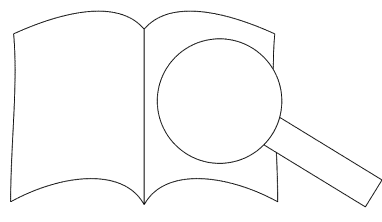

PROBENPAPIER
Ausgabequalität gegenüber Original evtl. gemindert • Evaluation Copy - Quality may be reduced • Carus-Verlag

son, Chri-ste e - le - - - i -

e - le - - - i - son, e - le - - - i -

- - i - son, e - le - - - i - son, e - le - i -

e - le - - - i - son,

Violoncelli

b3 - 43 - 6 - 43 - 6 [-] 43 - 6 - #3 - 6 - 43 - 6 6 #6 - 4 - 3

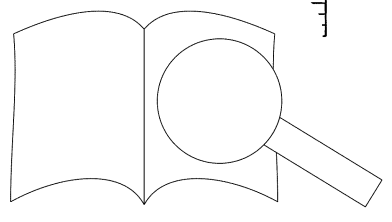

PROBEKOPPIERT
 Ausgabqualität gegenüber Original evtl. gemindert • Evaluation Copy - Quality may be reduced • Carus-Verlag

89

- i - son, e - le - i - son, e - le - i - son,

i Ky - ri - e e - le - i - son, Ky - ri - e e - le - - i -

- le - - - i - son, e - le - i - son, e - le - i - son, e - le - - -

- - - - i - son, e - le - i - son,

Violoncelle

7 #6 [-] 6 [-] 6 [-5] #3 3 6 [] 7 #3 7 #6 3 #3 #3 7 6 [4] 3 *) [b3-] [8] b9 8 7
 #4 5 5 4

*) Mozart schreibt b3. / Mozart's notation: b3.

PROBEKOPPIERT
 Ausgabequalität gegenüber Original evtl. gemindert • Evaluation Copy - Quality may be reduced • Carus-Verlag

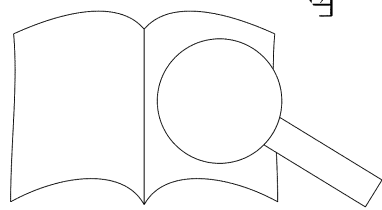

son, e - - son, Chri-ste e - - i -
 i - son, e - le - i - son, e - le - i - son, e - le - i - son,
 i - son, e - le - i - son, e - le - i - son,

5 [—] 6 6 5 6 — 6 — #3 — 6 — #3 — 6 [-] #3 [-] 6 6 [45] 7
 4 4 #3 [45] #

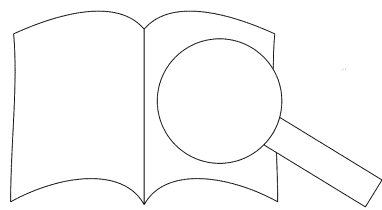

Violon₁

Adagio

96

le - son, e - le - i - son, Ky - ri - e e - le - i - son.

so - ri - e e - le - i - son, Ky - ri - e e - le - i - son.

Ky - ri - e e - le - i - son, Ky - ri - e e - le - i - son.

- i - son, e - le - i - son, e - le - i - son, Ky - ri - e

6 [-] #3 [-] 6 [45 -] #3 - 6 7 # 7 [5] 5 #3 7 5 7 #3 6 - 6 5 [43] #3

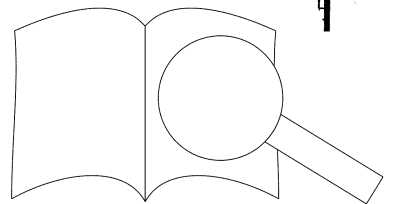

Sequenz

3. Dies irae

Allegro assai

Corno di Bassetto I, II
in Fa/F

Fagotto I, II

Clarino I, II
in Re/D

Timpani
in Re-La/D-A

Trombone alto

Trombone tenore

Trombone basso

Violino I

Violino II

Viola

Soprano

es i - rae, di - - es

- es i - rae, di - - es

Tutti

Di - - es i - rae, di -

Di - - es i - rae, di

Tutti

Violoncello,
Basso, Organo

f

5 6
4 5
2

9

- tus tre - mor est fu - tu - - rus,

Quan - - tus tre - mor est fu - tu - - rus,

Quan - - tus, quan - - tus tre - mor est fu -

Quan - - tus tre - mor est fu - tu .

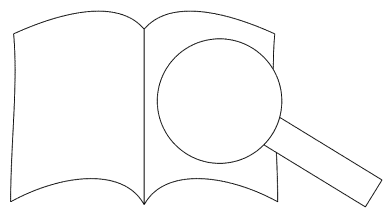

b7 ——— 6 ———
5 ———

PROBEPARTITUR
Ausgabequalität gegenüber Original evtl. gemindert • Evaluation Copy - Quality may be reduced • Carus-Verlag

quan - dex est ven - tu - - - rus,

ju - dex est ven - tu - - - rus,

quan - - - do ju - dex est ven -

- - - do ju - dex est ven - tu - -

4 ————— 13 ————— 7 [—————] 6 [—————]

13 ————— 5 [—————]

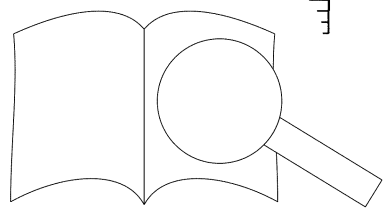

PROBEPARTITUR
 Ausgabqualität gegenüber Original evtl. gemindert • Evaluation Copy - Quality may be reduced • Carus-Verlag

cun - - - - - cte dis - cus - su - -

stri - - - - - cte dis - cus - su - -

n - - - cta stri - cte, stri - cte dis - cus - su - -

- cta stri - - - cte dis - cu

#6 4 3

6

7 3

#8 5 7

[#5 4 #8]

PROBEKOPPIE
 Ausgabequalität gegenüber Original evtl. gemindert • Evaluation Copy - Quality may be reduced • Carus-Verlag

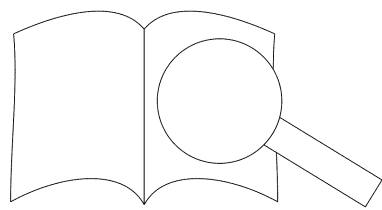

First system of musical notation, featuring a treble clef staff with a whole note chord and a bass clef staff with a melodic line starting on a quarter rest, marked with *a 2*.

Second system of musical notation, continuing the melodic line in the bass clef staff and a whole note chord in the treble clef staff.

Third system of musical notation, showing a grand staff with piano accompaniment in both hands.

Fourth system of musical notation, featuring a complex melodic line in the treble clef staff and a bass clef staff.

Fifth system of musical notation, including a vocal line with the word *rus!* and piano accompaniment.

Sixth system of musical notation, showing piano accompaniment in both hands.

Seventh system of musical notation, featuring a *Solo* section in the bass clef staff.

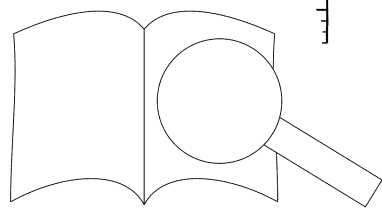

6 7 #6 6 6 6 6 #6 6 #6 6 6 6 - 45 -
 #5 #4 [43] [4] 4 4 - #3 -
 #3 3 3

PROBEPARTITUR
 Ausgabqualität gegenüber Original evtl. gemindert • Evaluation Copy - Quality may be reduced • Carus-Verlag

Di - - es il - la sol-vet sae-clum in fa-

i - rae, di - - es il - la sol-vet sae-clum in fa-

es i - rae, di - - es il - la sol-

utti

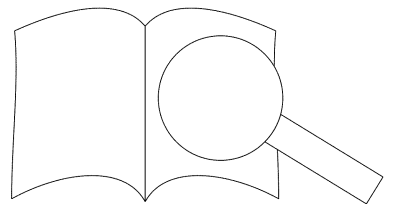

6 6

PROBENFÜR
Ausgabequalität gegenüber Original evtl. gemindert • Evaluation Copy - Quality may be reduced • Carus-Verlag

#6 6 6 6 b6 6 #5 [-] #6 8 7
 4 4 4 4 4 4 4 4 4 4
 3 3 3 3 3 3 3 3 3 3

PROBEKOPPIE
 Ausgabequalität gegenüber Original evtl. gemindert • Evaluation Copy - Quality may be reduced • Carus-Verlag

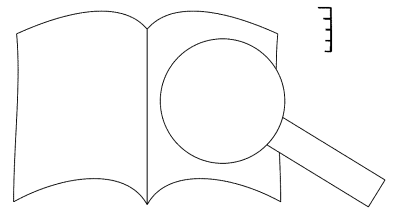

Quan - est fu - tu - rus, quan - - - do

- mor est fu - tu - rus, quan - - - do

as tre - mor est fu - tu - rus, quan - - - do

- - tus tre - mor est fu - tu - rus, qi

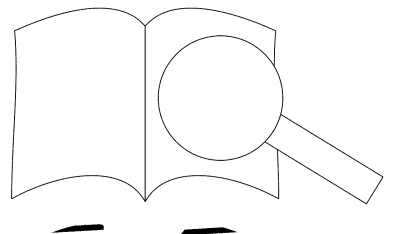

b8

6
4
b3

*) Vgl. Krit. Bericht. / Cf. Critical Commentary.

Musical notation for the first system, including vocal staves and piano accompaniment.

Empty musical staves for the second system.

Musical notation for the third system, including piano accompaniment.

Musical notation for the fourth system, including piano accompaniment.

ju - rus, cun - - cta stri - - cte

- tu - rus, cun - - cta stri - - cte

ven - tu - rus, cun - - cta stri - - cte

dex est ven - tu - rus, cun - - cta

Musical notation for the fifth system, including piano accompaniment.

Fingering diagrams for the piano accompaniment.

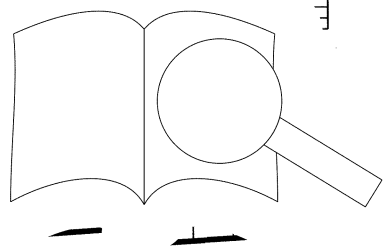

PROBEPARTITUR
 Ausgabequalität gegenüber Original evtl. gemindert • Evaluation Copy - Quality may be reduced • Carus-Verlag

39

dis - Di - es

su-rus! Di - es

- su-rus! Di - es

- - - - - cus - - - - - su-rus! Quan - tus tre - mor est fu -

b6 [] 7 [] 6 [4]5
 4 3 [] 4 #3

Organo: tasto solo

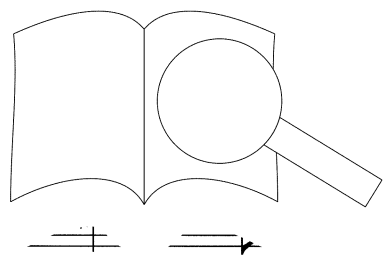

6 []

PROBEPARTITUR
 Ausgabqualität gegenüber Original evtl. gemindert • Evaluation Copy - Quality may be reduced • Carus-Verlag

Musical notation for the first system, including vocal line and piano accompaniment.

Musical notation for the second system, including vocal line and piano accompaniment.

Musical notation for the third system, including vocal line and piano accompaniment.

Musical notation for the fourth system, including vocal line and piano accompaniment.

Musical notation for the fifth system, including vocal line and piano accompaniment.

Musical notation for the sixth system, including vocal line and piano accompaniment.

Musical notation for the seventh system, including vocal line and piano accompaniment.

Musical notation for the eighth system, including vocal line and piano accompaniment.

PROBEPARTITUR
 Ausgabqualität gegenüber Original evtl. gemindert • Evaluation Copy - Quality may be reduced • Carus-Verlag

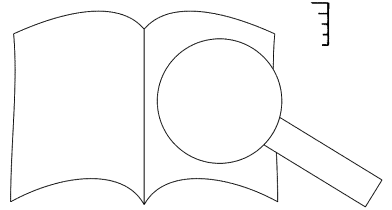

Tutti Bassi

Organo: tasto solo

$\frac{4}{3}$ 6 $\frac{4}{3}$ 6

6 []

47

i - r

quan - tus

il - la,

quan - tus

es il - la,

quan - tus

quan - tus tre - mor est_ fu -

Tutti Bassi

Organo: tasto solo

#4 6 #4 6 6

3 3 3

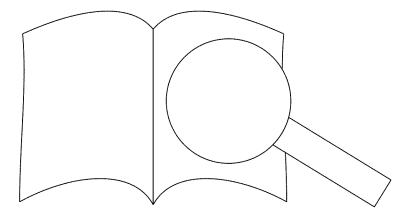

tre - rus, quan-do ju - dex est ven - tu - rus, cun-cta

- tu - rus, quan-do ju - dex est ven - tu - rus, cun-cta

est fu - tu - rus, quan-do ju - dex est ven - tu - rus, cun-cta

- mor est fu - tu - rus, quan-do ju - dex est ven

#4 6 #4 6 #4 6 #4 6 7 - # # # #
 b3 3 b3 3 b3 3 b3 3 15 #3 - -

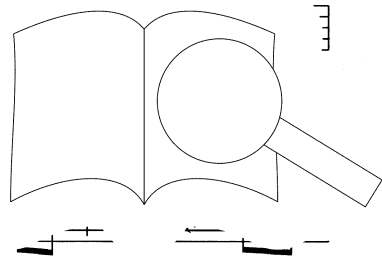

PROBENUR
 Ausgabqualität gegenüber Original evtl. gemindert • Evaluation Copy - Quality may be reduced • Carus-Verlag

55

stri - cte

cun - - cta stri - cte,

.s,

cun - - cta stri - cte,

- su - rus,

cun - - cta

dis - cus - su - rus,

Organo: tasto solo

6 6 6 5 6

PROBEPARTITUR

Ausgabequalität gegenüber Original evtl. gemindert • Evaluation Copy - Quality may be reduced • Carus-Verlag

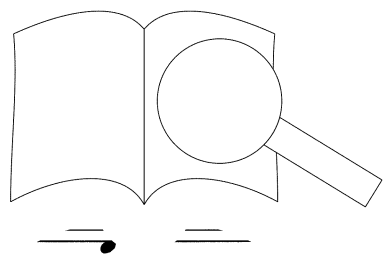

Musical notation for the first system, featuring a vocal line and a piano accompaniment.

Musical notation for the second system, featuring a vocal line and a piano accompaniment.

Musical notation for the third system, featuring a vocal line and a piano accompaniment.

Musical notation for the fourth system, featuring a vocal line and a piano accompaniment.

Musical notation for the fifth system, featuring a vocal line with lyrics and a piano accompaniment.

Musical notation for the sixth system, featuring a vocal line with lyrics and a piano accompaniment.

Musical notation for the seventh system, featuring a vocal line with lyrics and a piano accompaniment.

[5 —————] 7 ————— 7 ————— 4 [-] #3 [5 —————]

PROBEPARTITUR
 Ausgabegqualität gegenüber Original evtl. gemindert • Evaluation Copy - Quality may be reduced • Carus-Verlag

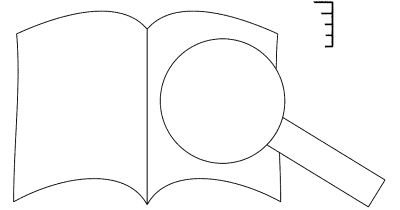

62

Musical notation for the first system, featuring a vocal line and piano accompaniment.

Musical notation for the second system, featuring a vocal line and piano accompaniment.

Musical notation for the third system, featuring a vocal line and piano accompaniment.

Musical notation for the fourth system, featuring a vocal line and piano accompaniment.

Musical notation for the fifth system, featuring a vocal line and piano accompaniment.

stri - - - - - stri - - - cte dis - cus - su - - -

stri - - - cte dis - cus - su - - -

- cta stri - cte, stri - - cte dis - cus - su - - -

an - - - cta stri - cte, stri - cte dis - cu

Fingering and chord diagrams for the piano accompaniment, including [5], b6, 5, 7, #, b5, 4, and #3.

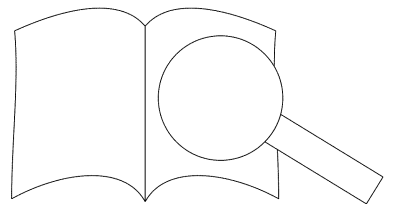

PROBEPARTITUR
Ausgabequalität gegenüber Original evtl. gemindert • Evaluation Copy - Quality may be reduced • Carus-Verlag

65

4 6 6 #3 #6 6 [4]6 6 6 #6 6 6 #6 6 6 6 #3

#4 3 b3 4 3 4

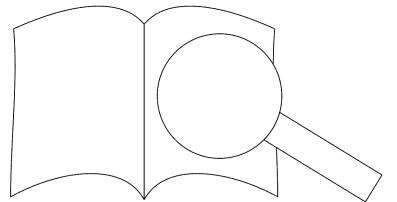

PROBEPARTITUR
 Ausgabequalität gegenüber Original evtl. gemindert • Evaluation Copy - Quality may be reduced • Carus-Verlag

4. Tuba mirum

Andante

Corno di Bassetto I, II
in Fa/F

Fagotto I, II

Trombone
tenore solo

Violino I

Violino II

Viola

Soprano solo

Alto solo

Tenore

Violoncello e Basso

The musical score is arranged in a standard orchestral format. It includes staves for Corno di Bassetto I, II in Fa/F; Fagotto I, II; Trombone tenore solo; Violino I; Violino II; Viola; Soprano solo; Alto solo; Tenore; and Violoncello e Basso. The Trombone tenore solo part features a melodic line starting with a forte (f) dynamic. The Violino I, Violino II, and Viola parts have a piano (p) dynamic. The vocal parts (Soprano, Alto, Tenore) are currently blank. The Violoncello e Basso part has a piano (p) dynamic. The score is in 3/4 time and the key signature has one flat (B-flat). The tempo is marked 'Andante'. A large watermark 'PROBE PARTITUR' is overlaid diagonally across the page. The Carus-Verlag logo is in the top right corner.

Tu - ba mi-rum spar-gens so - -

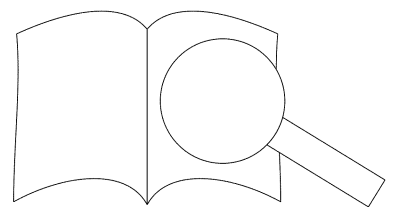

7

tu - ba mi-rum spar-gens so-num per se-pul-chra re-gi-o-num, co-get

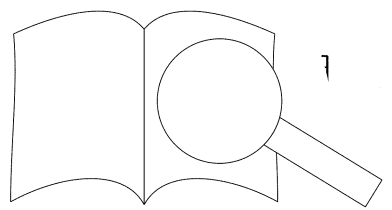

PROBENPARTITUR

Ausgabequalität gegenüber Original evtl. gemindert • Evaluation Copy - Quality may be reduced • Carus-Verlag

Mors stu-pe-bit et na-

u-num, co-get o - mnes an - te thro - - num.

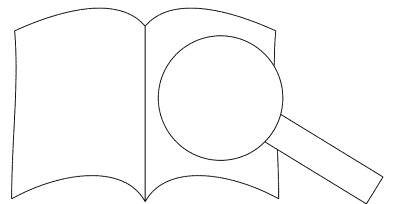

PROBENPARTEIFÜR
 Ausgabequalität gegenüber Original evtl. gemindert • Evaluation Copy - Quality may be reduced • Carus-Verlag

sur - get cre - a - tu - ra, ju - di - can - ti re - spon - su - ra.

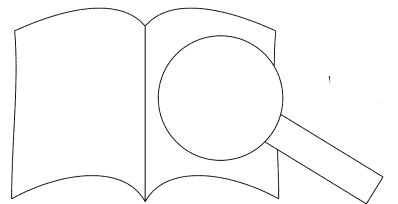

PROBEPARTITUR
 Ausgabequalität gegenüber Original evtl. gemindert • Evaluation Copy - Quality may be reduced • Carus-Verlag

ptus pro - fe - re - tur, in quo to - tum con - ti - ne - tur,

PROBE PARTITUR
 Ausgabequalität gegenüber Original evtl. gemindert • Evaluation Copy - Quality may be reduced • Carus-Verlag

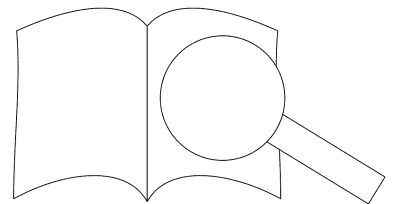

Ju - - dex

dus, mun - dus ju - - di - ce - - - tur.

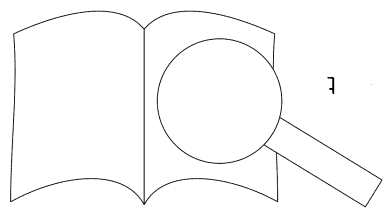

PROBEPARTITUR
 Ausgabequalität gegenüber Original evtl. gemindert • Evaluation Copy - Quality may be reduced • Carus-Verlag

er oit, quid - - quid la - tet ap - pa-

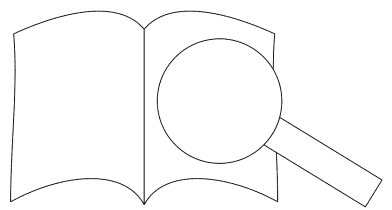

PROBEPARTITUR
Ausgabequalität gegenüber Original evtl. gemindert • Evaluation Copy - Quality may be reduced • Carus-Verlag

39

p 1.

re

sum mi - ser tunc di - ctu - rus? Quem pa-

re - bit.

Tutti Bassi

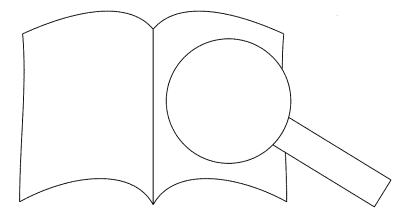

PROBE PARTITUR
 Ausgabequalität gegenüber Original evtl. gemindert • Evaluation Copy - Quality may be reduced • Carus-Verlag

43

tro - num

Cum vix ju-stus, ju-stus

sit se-

Violoncelli

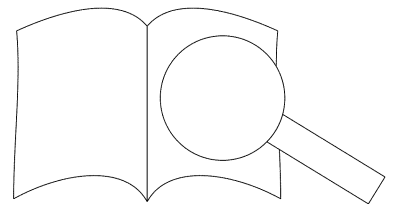

PROBEPARTITUR
 Ausgabequalität gegenüber Original evtl. gemindert • Evaluation Copy - Quality may be reduced • Carus-Verlag

50

sotto voce

sotto vor

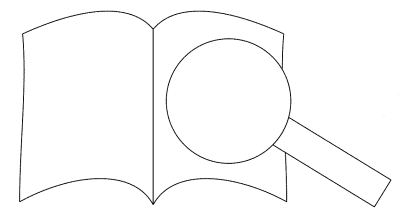

PROBE-PARTITUR
 Ausgabequalität gegenüber Original evtl. gemindert • Evaluation Copy - Quality may be reduced • Carus-Verlag

f p *crescendo* *f* *pp*

f p *crescendo* *f* *crescendo* *p*

cu - rus, cum vix ju - stus, - - rus.

cu - rus, cum sit se - cu - - rus.

cu - rus, vix ju - stus sit se - cu - - rus.

ju - stus, vix ju - stus sit se - cu - - rus.

f p *crescendo* *f*

PROBEKOPPIE
 Ausgabequalität gegenüber Original evtl. gemindert • Evaluation Copy - Quality may be reduced • Carus-Verlag

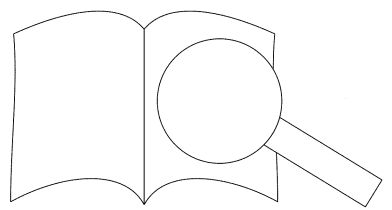

4

Rex, Rex, Rex tre-men-dae ma - je-

Rex, Rex tre-men-dae ma - je-

Rex, Rex tre-men-dae ma - je-

Rex, I

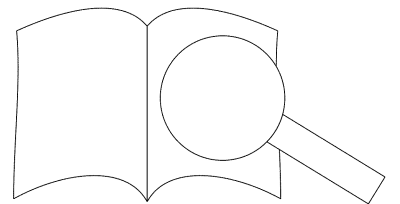

*) Bezifferung T. 6-17 aus dem Erstdruck der Stimmen. / Figuration for mm. 6-17 is taken from the first edition of the parts.

7

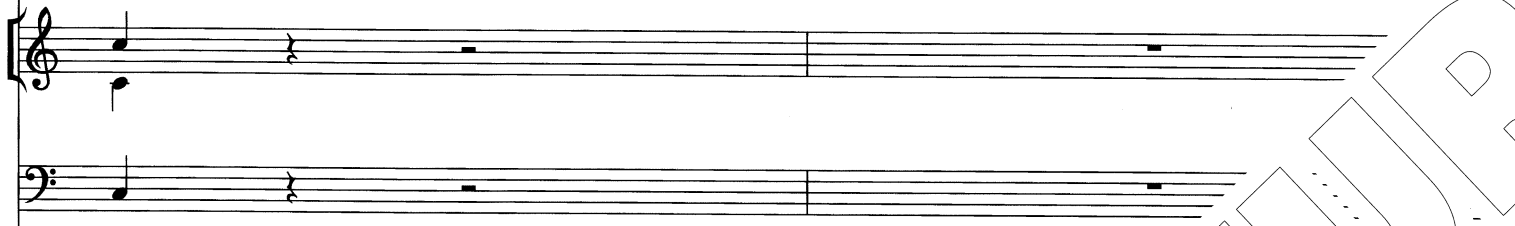

sta - tis, rex tre - men - - - - - dae ma - je -



men - - - - - dae ma - je - sta - - - - -

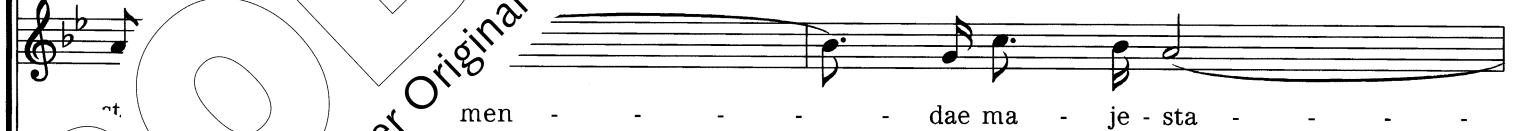

qui sal - van - dos sal - vas



- tis, qui sal -



5 [5] 7 8 5 7 8 6

PROBEPARTITUR
Ausgabequalität gegenüber Original evtl. gemindert • Evaluation Copy - Quality may be reduced • Carus-Verlag

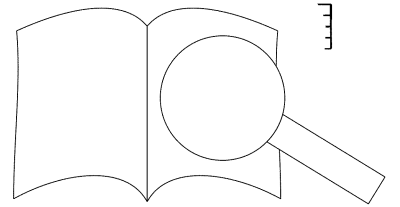

9

sta - - - - - dae ma - je - sta-tis, Rex tre-men-dae ma - je -

- - - - - dae ma - je - sta - - - - - tis, Rex tre-men-dae ma - je -

qui sal-van-dos sal - vas gra - - - - - tis, Rex tre-men-dae ma - je -

sal - vas gra-tis, sal - vas gra - - - - - tis, I

7 — 8 — 5 7 — 8 [—] 6 7 — 7 — 6 — 6 6 [4] 6 4 6 6 6 [7] 5

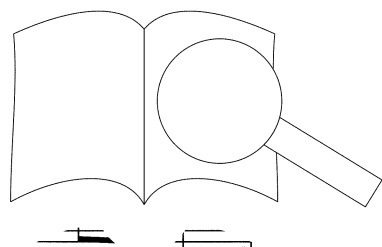

PROBEEPARTEUR
 Ausgabqualität gegenüber Original evtl. gemindert • Evaluation Copy - Quality may be reduced • Carus-Verlag

sta - tis, sal - van - dos sal - vas

st qui sal - van - dos

tre - men - - - - - dae ma - je - sta - - - -

is, Rex tre - men - - - -

#3 — 5 — 7 — 8 — 5[4]3

PROBEKOPPIE
 Ausgabequalität gegenüber Original evtl. gemindert • Evaluation Copy - Quality may be reduced • Carus-Verlag

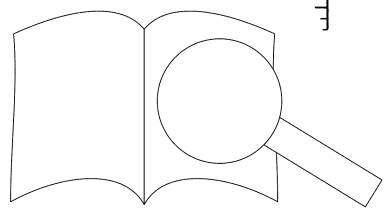

Musical notation for the first system, featuring a vocal line and piano accompaniment.

Musical notation for the second system, featuring a vocal line and piano accompaniment.

Musical notation for the third system, featuring a vocal line and piano accompaniment.

Musical notation for the fourth system, featuring a vocal line and piano accompaniment.

Musical notation for the fifth system, featuring a vocal line and piano accompaniment.

gra - tis,

s.

v. „is,

Rex

tre - men - dae ma - je -

tre - men -

- dae, Rex

tre - men - dae ma - je -

- - - - - tis, Rex

tre - men - dae, Rex

tre - me

47 — 8 — [4]5 5 — 9 — 8 — 7[4]5 — 6 [—]
 7 — 3 — 5 #3 —]
 5

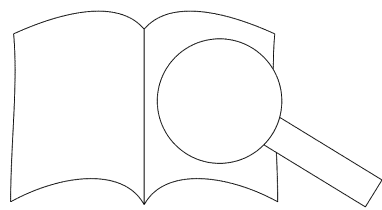

PROBENPAPIER
 Ausgabqualität gegenüber Original evtl. gemindert • Evaluation Copy - Quality may be reduced • Carus-Verlag

16

p

sta - tis, - tis, Sal - va me,
sta v. sal - vas gra - tis, Sal - va me,

-van-dos sal - vas gra - tis,
qui sal - van - dos sal - vas gra - tis,

Solo
p Organo: tasto solo

6 [4] 5
4 #3

[#]

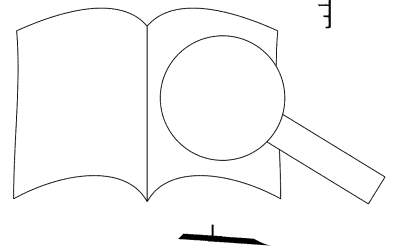

p

me, fons pi - e - ta - - - tis.

sal - va me, fons pi - e - ta - - - tis.

p

sal - va me, fons pi - e - ta - - - tis.

p

sal - va me, fons pi - e - ta - - -

Tutti

[8	7	b6	7	b6	-	6	-	b5	-
[b6			5	#4	-	4	-	#3	-
				[3	-				

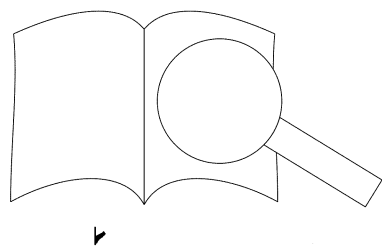

PROBEPARTITUR

Ausgabequalität gegenüber Original evtl. gemindert • Evaluation Copy - Quality may be reduced • Carus-Verlag

6. Recordare

Corno di Bassetto I
in Fa/F

Corno di Bassetto II
in Fa/F

Fagotto I

Fagotto II

Violino I

Violino II

Viola

Soprano solo

Alto solo

Tenor

Violoncello,
Basso, Organo

Violoncelli
Solo*)

p

tr

*) In allen Quellen unbeziffert. / Unfigured in all sources.



6

Fig. I/III

p

Tutti Bassi

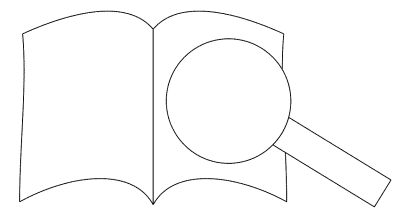

PROBE-PARTITUR
Ausgabequalität gegenüber Original evtl. gemindert • Evaluation Copy - Quality may be reduced • Carus-Verlag

cor - da - - - re

Re - - - cor re

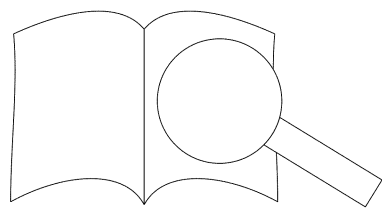

PROBEPARTITUR
 Ausgabequalität gegenüber Original evtl. gemindert • Evaluation Copy - Quality may be reduced • Carus-Verlag

Je - su - sum cau - - - sa

Je - su -

Quod - - - - - sum cau - sa

pi - - e,

Violoncelli

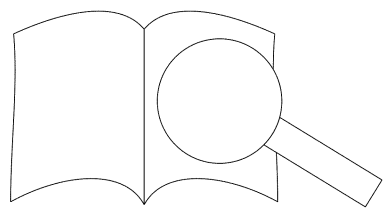

PROBEPARTITUR

Ausgabequalität gegenüber Original evtl. gemindert • Evaluation Copy - Quality may be reduced • Carus-Verlag

p
Fg. I
Fg. II
p

p
Fg. I
Fg. II
p

tu - ae - - - - - ne me per - das il - la
ne me
- - - - - ae: ne me per - das il - la
ne me per - das il

Tutti Bassi

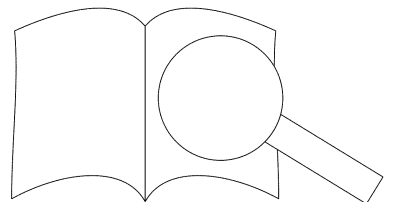

di - - e, n' la_ di - - e.

per - das, il - la di - - e.

me per - das il - la di - - e.

per - das, per - das il - la di - - e.

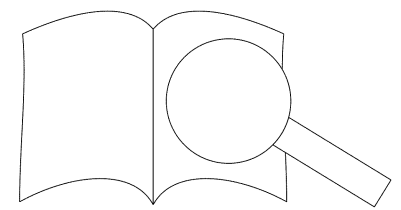

PROBEPARTITUR

Ausgabequalität gegenüber Original evtl. gemindert • Evaluation Copy - Quality may be reduced • Carus-Verlag

36

Fg. I/II

a 2

tr

tr

p

Se - di - sti

Se - di - sti

Quae - rens me,

Tutti Bassi

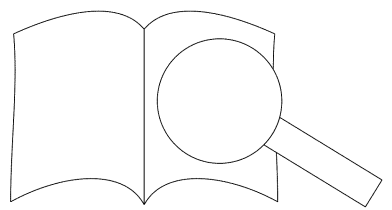

PROBE PART FÜR
 Ausgabequalität gegenüber Original evtl. gemindert • Evaluation Copy - Quality may be reduced • Carus-Verlag

First system of piano accompaniment, measures 41-46. It consists of three staves: treble, middle, and bass. The music features a mix of eighth and sixteenth notes with some rests.

Second system of piano accompaniment, measures 47-52. It consists of three staves. A trill (tr) is marked above a note in the first measure of the top staff.

Vocal line for the first system, measures 41-46. The notes are mostly whole and half notes.

las - sus:

cru - cem pas - sus:

tan - tus

Vocal line for the second system, measures 47-52. The notes are mostly whole and half notes.

las - sus:

cru - cem pas - sus:

tan - tus

Vocal line for the third system, measures 41-46. The notes are mostly whole and half notes.

- mi - sti

tan - tus

Vocal line for the fourth system, measures 41-46. The notes are mostly whole and half notes.

red - - e - mi - sti

tan - tus

Final system of piano accompaniment, measures 41-46. It consists of three staves with a more active melodic line in the top staff.

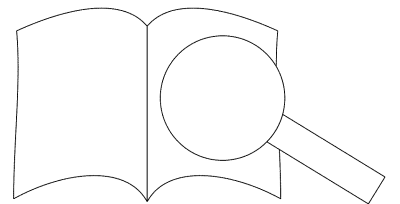

PROBE PARTIEMUR
 Ausgabequalität gegenüber Original evtl. gemindert • Evaluation Copy - Quality may be reduced • Carus-Verlag

Piano accompaniment for the first system, measures 47-50. It consists of three staves: two treble clefs and one bass clef. The music features flowing sixteenth-note patterns in the bass and more melodic lines in the treble.

Piano accompaniment for the second system, measures 51-54. It consists of three staves. The bass line includes trills marked with 'tr' in measures 52 and 54.

Vocal line with lyrics for the first system, measures 47-50. The lyrics are: la - bor non sus, tan - tus la-bor non sit cas - -

Vocal line with lyrics for the second system, measures 51-54. The lyrics are: la - bor cas - sus, tan - tus la-bor non sit cas - -

Vocal line with lyrics for the third system, measures 55-58. The lyrics are: .on sit cas - sus, tan - tus la-bor non sit cas - -

Vocal line with lyrics for the fourth system, measures 59-62. The lyrics are: non sit cas - sus, tan - tus la-bor non sit cas - -

Piano accompaniment for the fifth system, measures 63-66. It consists of a single treble clef staff with a melodic line.

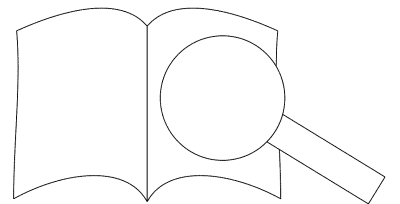

Empty musical staves for piano accompaniment, consisting of two grand staff systems (treble and bass clefs).

Musical notation for piano accompaniment, including treble and bass clefs with various notes and rests.

Vocal line with lyrics:
 sus. Ju - dex ul - ti - o - nis,
 sus.
 sus. Ju - ste ju - dex ul-ti - o - nis, do -

Violoncelli
 Musical notation for the cello part, starting with a treble clef and a 13-measure rest.

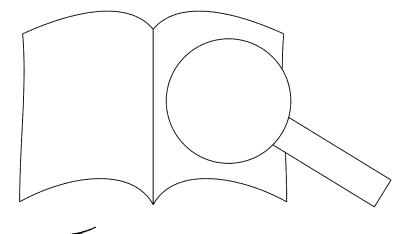

PROBE PARTITUR
 Ausgabequalität gegenüber Original evtl. gemindert • Evaluation Copy - Quality may be reduced • Carus-Verlag

p

Fg. I

Fg. II

do - num fac re- mis-si an - te di - em ra - ti -

An - te

-1 - - nis, an - te di - em ra - ti -

an - te di - em ra - ti - nis,

Tutti Bassi

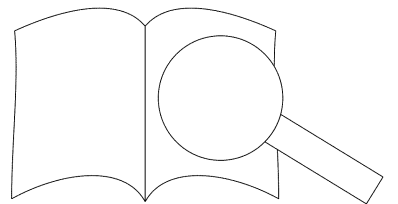

o - - nis, an - di o - nis.

di - - em ra - ti - o - nis.

o - di - em ra - ti - o - nis.

di - em, di - em ra - ti - o - nis.

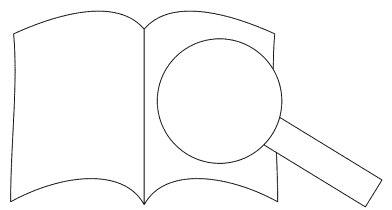

PROBEPARTITUR
Ausgabequalität gegenüber Original evtl. gemindert • Evaluation Copy - Quality may be reduced • Carus-Verlag

Fg. I/II

f

p

tr

f

ai - sco, tam-quam re - us:

In - ge - mis - co, tam-quam re - us:

In - ge - mi - sco, tam-quam re - us:

In - ge - mi - sco, tam-quam re - us:

Tutti Bassi

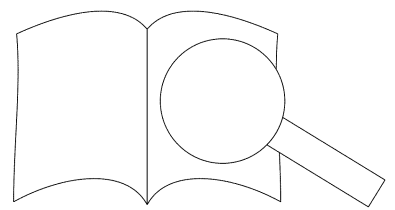

76

cul - pa ru - b: sup - pli - can - ti

cul - pa tus me - us: sup - pli - can - ti

vul - tus me - us: sup - pli - can - ti

u - bet vul - tus me - us: sup - pli - can - ti

PROBEPARTITUR
Ausgabequalität gegenüber Original evtl. gemindert • Evaluation Copy - Quality may be reduced • Carus-Verlag

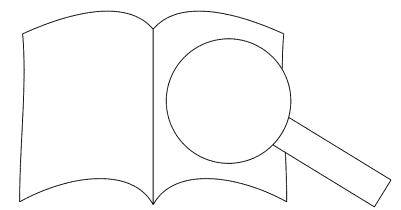

Empty musical staves for piano accompaniment, consisting of three systems of two treble and one bass clef staves.

Musical notation for piano accompaniment, consisting of three systems of two treble and one bass clef staves with notes and rests.

Musical notation for voice part 1, consisting of a single treble clef staff with notes and rests.

par - ce De - us. -ri mi-hi quo - que spem de-

Musical notation for voice part 2, consisting of a single treble clef staff with notes and rests.

par - ce mi-hi quo-que, mi - hi

Musical notation for voice part 3, consisting of a single treble clef staff with notes and rests.

ce et la- tro - nem ex-au - di-sti, mi - hi

Musical notation for piano accompaniment, consisting of a single bass clef staff with notes and rests.

De - us.

Musical notation for piano accompaniment, consisting of a single bass clef staff with notes and rests.

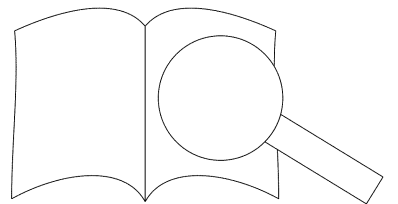

PROBE-PARTITUR
 Ausgabequalität gegenüber Original evtl. gemindert • Evaluation Copy - Quality may be reduced • Carus-Verlag

89

p *f p*

f p

di - sti, mi - hi quo - que

quo - que spem

Pre - - - ces me - - - ae

spem de - di - sti.

quo - que spem de - di - sti. Pre - - -

f p

PROBEPARTITUR
 Ausgabequalität gegenüber Original evtl. gemindert • Evaluation Copy - Quality may be reduced • Carus-Verlag

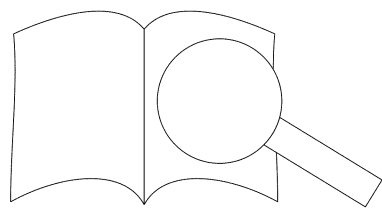

non si' tu bo - - - nus

Sed tu bo - -

sunt di - - gnae:

Violoncelli

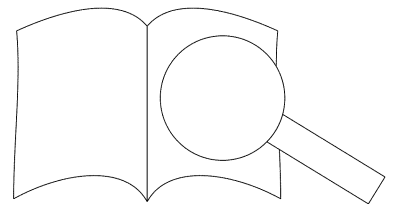

In - cum prae - sta, et ab hae - dis me -
 ves lo - cum prae - sta, et ab hae - dis me
 o - ves lo - cum prae - sta, et ab hae

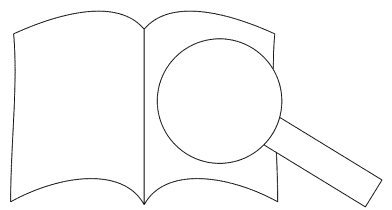

PROBENPARTITUR

Ausgabequalität gegenüber Original evtl. gemindert • Evaluation Copy - Quality may be reduced • Carus-Verlag

Fg. I/II

par - - - te dex .

par - -

p:

- te dex - tra.

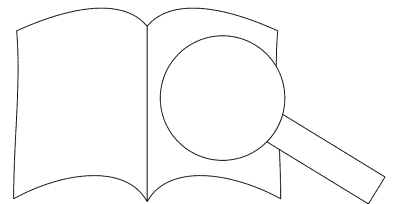

7. Confutatis

Andante

Corno di Bassetto I, II
in Fa/F

Fagotto I

Fagotto II

Trombone alto

Trombone tenore

Trombone basso

Violino I

Violino II

Viola

Soprano

Alto

f Tutti

f Tutti

Con - fu - ta - tis ma - le-

Con - fu-ta - tis ma -

Tutti

violoncello,
Basso, Organo

f
Organo: *tasto solo*

3

flam - mis a - cri-bus ad-
 flam - mis a - cri-bus ad - di - - ctis,

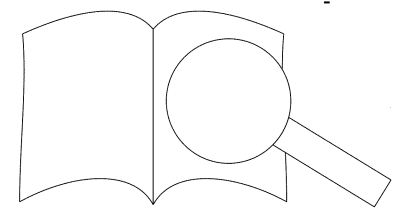

PROBEPARTITUR
 Ausgabequalität gegenüber Original evtl. gemindert • Evaluation Copy - Quality may be reduced • Carus-Verlag

ossia: *p*
[od./or $\frac{1}{4}$]

5

ossia: *p*
[od./or $\frac{1}{4}$]

Tutti *sotto voce*
Vo - - ca, vo - ca me,
Tutti *sotto voce*
Vo - - ca, vo - ca me,

a - cri-bus ad - di - ctis,
d' flam - mis a - cri-bus ad - di - ctis,

Solo
p

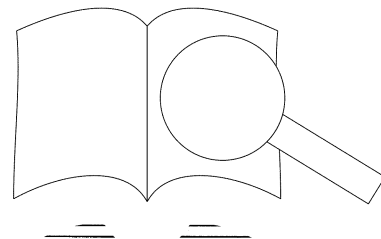

9

vo - c^o - ctis.

vo - ctis.

Con - fu - ta - - tis

Con - fu - ta - - tis le-

Tutti

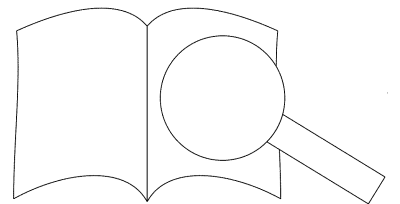

Musical notation for the first system, featuring a vocal line in the upper staff and piano accompaniment in the lower staves.

Musical notation for the second system, featuring a vocal line in the upper staff and piano accompaniment in the lower staves.

Musical notation for the third system, featuring a vocal line in the upper staff and piano accompaniment in the lower staves.

Musical notation for the fourth system, featuring a vocal line in the upper staff and piano accompaniment in the lower staves.

Musical notation for the fifth system, featuring a vocal line in the upper staff and piano accompaniment in the lower staves.

ae-di - - ctis, flam - - - mis a - cri - bus ad-
 - cis, flam - mis a - cri - bus ad-di

Musical notation for the sixth system, featuring a vocal line in the upper staff and piano accompaniment in the lower staves.

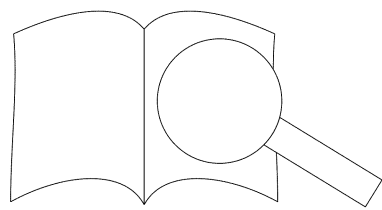

PROBENPAPIER
 Ausgabequalität gegenüber Original evtl. gemindert • Evaluation Copy - Quality may be reduced • Carus-Verlag

Musical notation for the first system, featuring a treble clef and two bass clefs. The music consists of several measures with notes and rests. A dynamic marking 'p' is present in the final measure of the system.

Musical notation for the second system, featuring a treble clef and two bass clefs. The music consists of several measures with notes and rests.

Musical notation for the third system, featuring a treble clef and two bass clefs. The music consists of several measures with notes and rests. Dynamic markings 'p' are present in the final measures of the system.

Musical notation for the fourth system, featuring a treble clef and two bass clefs. The music consists of several measures with notes and rests.

. - tis ma - le - di - ctis, flam - mis a - cri - bus ad - di - ctis,
 .a - le - di - ctis, ma - le - di - ctis, flam - mis a - cri - bus

Musical notation for the fifth system, featuring a treble clef and two bass clefs. The music consists of several measures with notes and rests.

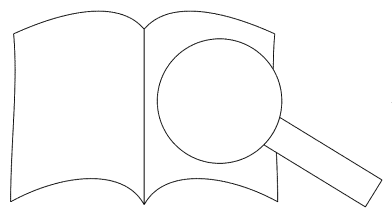

PROBENPARTITUR
 Ausgabequalität gegenüber Original evtl. gemindert • Evaluation Copy - Quality may be reduced • Carus-Verlag

sotto voce

Vo - - - be-ne- di - ctis, cum be - ne - di - ctis, vo -

sotto voce

Vo - - - ca me, vo - ca me cum be-ne -di - ctis,

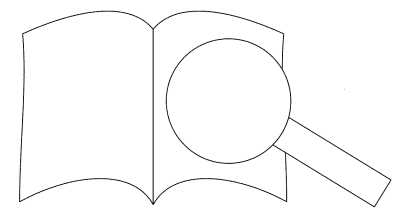

PROBEPARTITUR

Ausgabequalität gegenüber Original evtl. gemindert • Evaluation Copy - Quality may be reduced • Carus-Verlag

Fg. I/II

- ca me, vo - ca me cum be-ne - di - - -

vo - ca me cum be - ne - di - - -

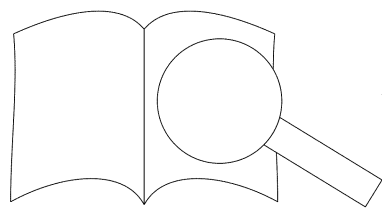

PROBEPARTITUR

Ausgabequalität gegenüber Original evtl. gemindert • Evaluation Copy - Quality may be reduced • Carus-Verlag

First system of musical notation, including treble and bass clefs, a key signature of one sharp (F#), and dynamic markings such as *p* (piano).

Second system of musical notation, including treble and bass clefs, and dynamic markings such as *p* (piano).

Third system of musical notation, including treble and bass clefs, and dynamic markings such as *p* (piano).

Vocal line with lyrics: *ctis. O - ro sup - plex et ac -*. Includes dynamic markings such as *p* (piano).

Section labeled *Tutti* with musical notation and chord diagrams below it.

Chord diagrams for the *Tutti* section, showing fingerings for chords: 6, 4, #2 and b7, b5, 8.

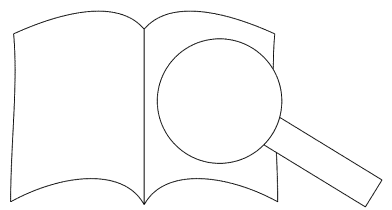

PROBE PAPIER
 Ausgabqualität gegenüber Original evtl. gemindert • Evaluation Copy - Quality may be reduced • Carus-Verlag